

The Role of Neural Mechanisms of Attention in Solving the Binding Problem

Review

John H. Reynolds* and Robert Desimone
Laboratory of Neuropsychology
National Institute of Mental Health
Bethesda, Maryland 20892

For purposes of this review, we will define the binding problem as the problem of how the visual system correctly links up all the different features of complex objects. For example, when viewing a person seated in a blue car, one effortlessly sees that the person's nose belongs to his face and not to the car, and that the car, but not the nose, is blue. To fully understand the solution to this problem requires a good neurobiological theory of object recognition, which does not exist. We will therefore follow the lead of the computer engineer, who, when asked to describe how he would write a computer program to recognize a chicken, replied, "first, assume a spherical chicken." Thus, in this review we will make some assumptions that simplify the binding problem in order to appreciate how neural mechanisms of attention provide a partial solution.

Evidence for the Binding Problem

Before getting to the mechanisms of attention, it is useful to consider the psychological and physiological evidence that the binding problem even exists. The classic psychological evidence comes from studies of "illusory conjunctions" (Treisman and Schmidt, 1982; Cohen and Ivry, 1989; Ivry and Prinzmetal, 1991; Arguin et al., 1994; Prinzmetal et al., 1995). In a typical experiment, human subjects are briefly presented with an array containing several different objects, such as letters of the alphabet, shown in different colors. In one condition, subjects are cued to attend to one of the letters, and in a comparison condition their attention is divided between the array and another object. In the former condition, with undivided attention, the letter is perceived correctly. However, in the latter condition, with divided attention, subjects often perceive the wrong combinations of letters and colors, e.g., a red letter B and green letter C are misperceived as a green B and a red C. That is, color and shape are incorrectly bound.

These studies argue that the binding problem exists and that attention helps to solve it. Consistent with this interpretation, damage to the parietal lobes, which are thought to be involved in allocating attention, can result in illusory conjunctions during free viewing. Patient R. M. suffered two successive strokes that caused extensive bilateral parietooccipital lesions that spared the temporal and frontal lobes. He was severely impaired in attentionally demanding visual tasks, and, when presented with two colored letters, he often misconjoined their identities and colors, even after viewing for up to 10 s (Friedman-Hill et al., 1995). By contrast, he was much

less impaired on less attentionally demanding tasks such as detecting a "popout" stimulus.

The physiological evidence for the binding problem comes from studies of neurons in extrastriate visual cortex of primates. One key observation is that different features of an object are processed to a certain extent by different neurons within the visual system. For example, some neurons in areas V2 and V4 respond selectively to the orientation of an object, independent of its color, whereas other V2 and V4 neurons respond selectively to color, independent of shape, and cells selective for different features are often located in separate regions of both areas (Schein et al., 1982; Livingstone and Hubel, 1983; Desimone et al., 1985; Tanaka et al., 1986b; Schein and Desimone, 1990; Ghose and Ts'o, 1997). Still other neurons in the middle temporal area (MT) and the medial superior temporal area (MST) encode various aspects of the motion of the stimulus (Desimone and Ungerleider, 1986; Saito et al., 1986; Tanaka et al., 1986a, 1989; Rodman and Albright, 1989; Stoner and Albright, 1992; Geesaman and Andersen, 1996; Treue and Andersen, 1996; Bradley et al., 1998; Buračas et al., 1998; O'Keefe and Movshon, 1998; Lisberger and Movshon, 1999). Logically, in order to identify the shape, color, and motion of a stimulus, the visual system must somehow integrate the activity of these different shape-selective, color-selective, and motion-selective neurons. When only one stimulus is present in the visual field, this is not a difficult problem because these features can only be assigned to one possible stimulus. However, when multiple stimuli appear together in the visual field, which is the typical situation in "real-world" scenes, the visual system must assign the correct color, shape, and motion signals to each object.

If all neurons were highly selective for spatial location, then illusory conjunctions might be avoided by integrating features separately at each precise location in the visual field. For example, one might integrate color and shape only for neurons that share the same receptive field. However, as one moves through the ventral visual stream that underlies object recognition (Ungerleider and Mishkin, 1982), the receptive field size of neurons increases steadily. Neurons in area V4, for example, typically have receptive fields that are several degrees wide near the representation of the center of gaze, and neurons in the inferior temporal (IT) cortex have receptive fields that can include the entire central visual field, on both sides of the vertical midline (Desimone et al., 1984; Desimone and Schein, 1987; Gattass et al., 1988). These large receptive fields are presumably necessary to recognize large complex objects and may mediate the ability to recognize objects of any size as the same, regardless of their retinal location. The ventral stream cortical areas with large receptive fields are known to play an important role in object recognition, because recognition is greatly impaired when these areas are damaged (Covey and Gross, 1970; Gross et al., 1971; Dean, 1976; Ungerleider and Mishkin, 1982).

Similarly, information about the motion of visual patterns appears to be processed in areas within the dorsal

* To whom correspondence should be addressed (e-mail: reynolds@ln.nimh.nih.gov).

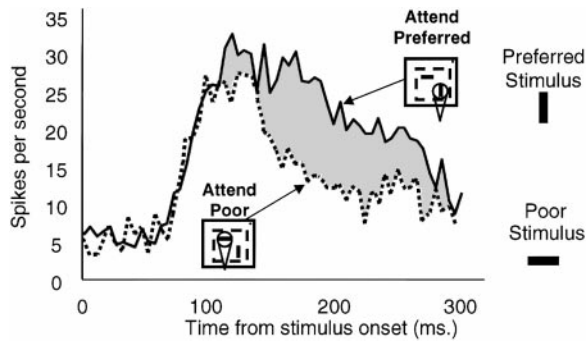

Figure 1. Average Response over Time of a Population of Stimulus-Selective V4 Neurons to Two Stimuli inside the Classical Receptive Field

When attention was directed to the poor stimulus (bottom line), responses were lower than when attention was directed to the preferred stimulus (top line).

stream that have large receptive fields. When a complex pattern, such as a plaid, moves through the visual field, neurons in primary visual cortex respond selectively to the direction of movement perpendicular to the lines that make up the plaid. However, some neurons in area MT, an area with large receptive fields, respond according to the direction of motion of the plaid as a whole (Gizzi et al., 1983; Movshon et al., 1985; Rodman and Albright, 1989; Stoner and Albright, 1992). Position-invariant object identity and global pattern motion are just two of many examples of stimulus attributes that appear to be represented in areas whose neurons have large receptive fields.

The number of potentially erroneous feature conjunctions increases exponentially with the number of objects in a large receptive field (Tsotsos, 1990). As receptive fields become larger and larger at each processing stage of the ventral stream, there is therefore an increasing number of erroneous feature bindings to rule out. Thus, the binding problem emerges as a necessary consequence of the large receptive fields found in higher-order areas.

Attention and Shrinking Receptive Fields

A possible solution to the binding problem was suggested by the study of Moran and Desimone (1985), who found that when two stimuli appear within the receptive field of a neuron in either area V4 or inferior temporal cortex, the response elicited by the pair depends on which of the two stimuli is attended. They chose the shape and color of the stimuli such that one of the stimuli elicited a strong response when it was presented alone (the *preferred* stimulus), whereas the other elicited a very weak response when it was presented alone (the *poor* stimulus). When attention was directed to the preferred stimulus, the pair elicited a strong response. However, when attention was directed to the poor stimulus, the identical pair elicited a weak response, even though the preferred stimulus was still in its original location (see Figure 1).

Luck et al. (1997a) and Reynolds et al. (1999) replicated this result in area V4 and found it to hold in area V2 as well. Treue and Maunsell (1996) have reported the

same pattern of results in areas MT and MST. They presented a preferred stimulus (a dot moving in the cell's preferred direction) together with a poor stimulus (a dot simultaneously moving in the opposite direction) within the receptive field. The responses elicited by the pair were higher when attention was directed to the dot moving in the preferred direction, relative to when attention was directed to the dot moving in the opposite direction. A similar experiment recently conducted by Seidemann and Newsome (1999) also found that when two stimuli appear within the receptive field of an MT neuron, attention to the more-preferred stimulus increases responses, relative to when attention is directed to the poorer stimulus. However, the magnitude of these effects was much smaller than that observed by Treue and Maunsell (1996), suggesting that the degree to which attention is able to modulate neuronal responses and the stage of processing at which this occurs may be task dependent.

One way to account for these results is to assume that when attention is directed to one of two stimuli within a cell's receptive field, this causes the receptive field to constrict around the attended stimulus, leaving the unattended stimulus outside the receptive field (see Figure 2). According to this interpretation, when attention is directed to the preferred stimulus, the neuron is driven by the preferred stimulus, and its response is therefore large. When attention is directed to the poor stimulus, the preferred stimulus is now excluded from the receptive field, the cell is driven by the poor stimulus, and its response is small. Thus, according to this interpretation, attention solves the binding problem by increasing the effective spatial resolution of the visual system so that even neurons with multiple stimuli inside their large receptive fields process information only about stimuli at the attended location.

Further support for the idea that attention increases the spatial resolution of the visual system comes from two recent psychophysical studies. In one (Yeshurun and Carrasco, 1999), subjects were tested in three different tasks that required them to make fine spatial discriminations. In all three tasks, subjects responded more slowly and less accurately when the stimulus appeared at more peripheral locations, where receptive fields are larger. And, in all three tasks, directing attention to the location of the stimulus resulted in faster and more accurate performance. In a related study, Yeshurun and Carrasco (1998) also found that attention paradoxically impairs performance in a task that requires processing of low-spatial frequency components of a stimulus. Subjects were asked to detect the presence of a texture-defined target, which required integration of information at low spatial resolution. Unlike most visual tasks, performance on this detection task is poorer at the fovea than it is at mid-peripheral locations, where spatial resolution is most appropriate for the task (DeValois and DeValois, 1988; Graham, 1989). Yeshurun and Carrasco found that attention improved performance on this task at peripheral locations, presumably by increasing the spatial resolution of peripheral vision to better fit the task. Strikingly, attention significantly reduced performance on the foveal task, where further improvement of spatial resolution would be expected to undermine performance.

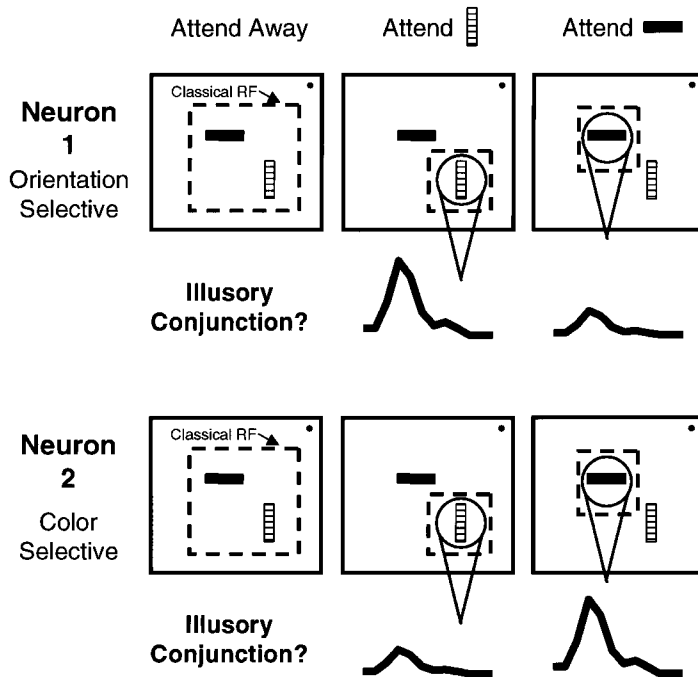

Figure 2. Schematic Diagram Illustrating How Attention May Resolve Illusory Conjunctions. Each row of three panels shows a schematic representation of the responses of a single hypothetical neuron. The orientation-selective neuron appearing in the upper row responds to a vertical bar appearing anywhere in its classical receptive field (dashed box at left), regardless of its color. The neuron appearing below responds selectively to a dark bar, regardless of its orientation. When attention is directed away from the receptive field, and both stimuli appear together, both neurons will be somewhat active, indicating the presence but not the exact location of their preferred features. Because the precise location of the two stimuli is not represented in the largely spatially invariant responses of the neurons, the neuronal response cannot unambiguously indicate whether the two features belong to the same stimulus. When attention is directed to one of the stimuli, both neurons respond according to the features of the attended stimulus. Since neurons respond as though only the attended stimulus were present, their activities can be unambiguously interpreted as reflecting features of a common, attended object.

The Role of Competition

Desimone and Duncan (1995) have proposed that such changes in spatial resolution may emerge as a result of competitive interactions between stimuli. According to this hypothesis, multiple stimuli in the visual field activate populations of neurons that engage in competitive interactions, possibly mediated through local, intracortical connections. When subjects are instructed to attend (or choose voluntarily to attend) to a stimulus at a particular location or with a particular feature, this generates signals within areas outside visual cortex. These signals are then fed back to extrastriate areas, where they bias the competition in these areas in favor of neurons that respond to the features or location of the attended stimulus. As a result, neurons that respond to the attended stimulus remain active while suppressing neurons that respond to the ignored stimuli. In other words, neuronal responses are now determined by the attended stimulus, and any unattended stimuli are filtered out of their classical receptive fields—an effective increase in the neurons' spatial selectivity.

For example, imagine recording from a neuron that responds vigorously to stimulus A and fails to respond to stimulus B. If attention is directed to stimulus A, this will bias the competition in favor of the population of cells that normally responds to A, and the cell being recorded will remain active. If attention is then directed to stimulus B, the competing population will win, and the cell being recorded will be suppressed, along with the other members of its population. In retinotopically organized areas, such as area V4, this competition is thought to be strongest for cells located near to one another in the cortex, which therefore share similar receptive fields.

We recently tested this idea that attention works through competitive processes by recording V2 and V4

neuronal responses in a behavioral paradigm that allowed us to isolate automatic sensory processing mechanisms from attentional ones (Reynolds et al., 1999). We first tested cells for competitive interactions in the absence of attention. While the monkey attended to a location far outside the receptive field of the neuron, we measured the response to a single reference stimulus within the receptive field. We then compared this response to the response when a probe stimulus was added within the receptive field. When the probe was added to the field, the neuron's response was drawn toward the response that would have been elicited if the probe had appeared alone. For example, the response to a preferred reference stimulus was typically suppressed when a poor stimulus was added as a probe, even when the poor stimulus elicited small excitatory responses when it appeared alone. Symmetrically, the response of the cell increased when a preferred probe stimulus was added to a poor reference stimulus. Thus, the response of a cell to two stimuli in its field is not the sum of its responses to both but rather is a weighted average of its response to each alone.

To test how attention influenced this automatic competitive mechanism, we then had the monkey attend to the reference stimulus. The effect of attending to the reference stimulus was to almost precisely eliminate the excitatory or suppressive effect of the probe. If, in the absence of attention, the probe stimulus had suppressed the response to the reference, then attending to the reference restored the cell's response to the level that had been elicited when the reference was presented alone (Figure 3A). Conversely, if the probe stimulus had increased the cell's response, attending to the reference stimulus drove the response down to the level that had been recorded when the reference was presented alone (Figure 3B). Thus, the effect of attention was to modulate the underlying competitive interaction between stimuli.

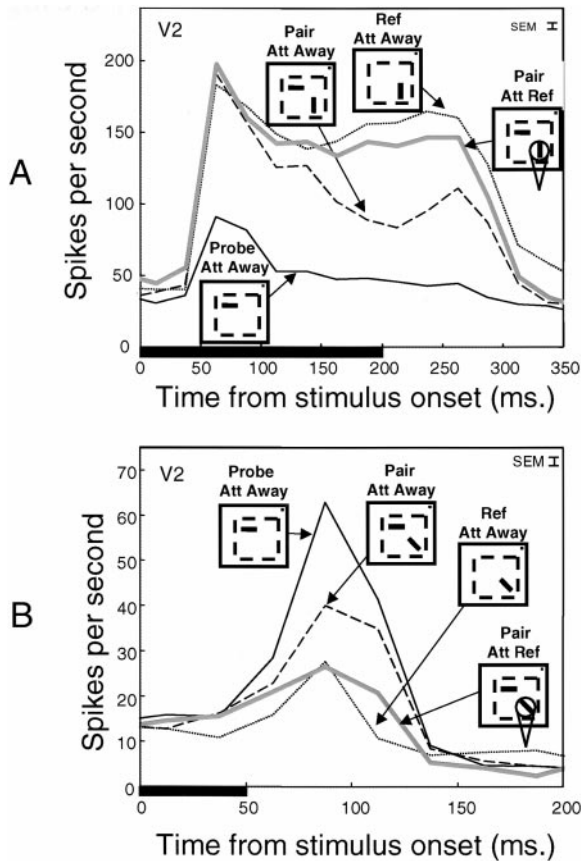

Figure 3. Responses of Single Neurons in Area V2, Showing that the Attended Stimulus Controls the Response of the Neuron (A) The dotted line at the top shows the response of a single V2 neuron to a stimulus of its preferred orientation and color. The solid line at the bottom shows the response to a poor stimulus. The dashed line in the middle shows the response when the two stimuli are presented together, with attention directed away from the receptive field. The addition of the poor stimulus strongly suppresses the response elicited by the preferred stimulus. When attention is directed to the preferred stimulus, this suppression is eliminated, and the neuron responds as though the poor stimulus were absent. (B) Here, the response of another V2 neuron to a poor stimulus (bottom dotted line) is increased (middle dashed line) by the addition of a preferred horizontal stimulus. When attention is directed to the poor stimulus, the cell's response is reduced to a level that is comparable to its response to the poor stimulus, alone.

Given the close similarities between attention effects in the dorsal and ventral streams, it seems likely that both streams use the same underlying competitive circuit. Consistent with this possibility, studies of neuronal responses to multiple stimuli have found opponent direction suppression in areas MT and MST of the dorsal stream (Qian and Andersen, 1994; Recanzone et al., 1997; see also Mikami et al., 1986). Responses to stimuli moving in a nonpreferred direction are increased by the addition of a second stimulus moving in the preferred direction in the receptive field, and, conversely, responses to preferred stimuli are suppressed by the addition of a stimulus moving in the null direction. It remains for future studies to confirm that attention modulates this underlying competitive circuit.

Recent functional magnetic resonance imaging (fMRI)

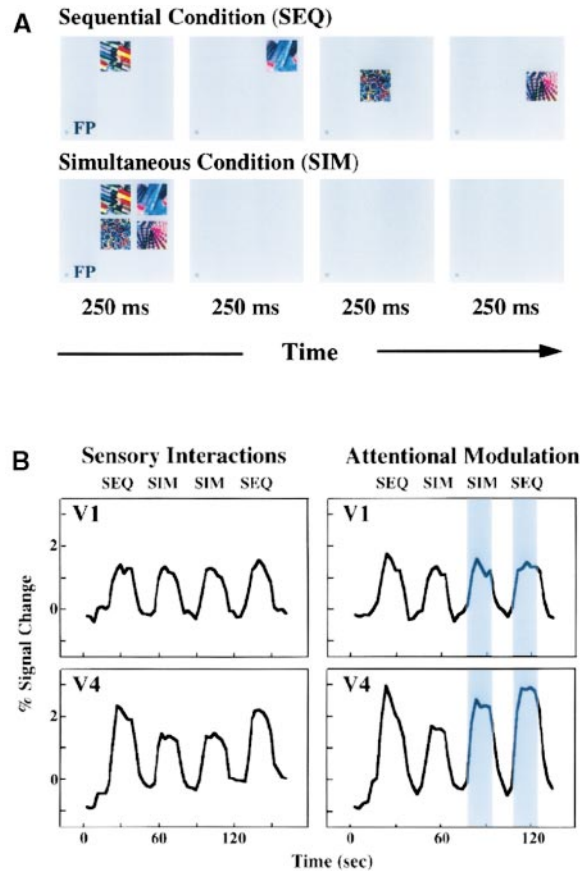

Figure 4. fMRI Signals in the Human Show Sensory Interactions and Attention Effects that Scale with the Size of Receptive Fields at Successive Cortical Areas

(A) Task. Subjects fixated a spot while stimuli appeared either asynchronously (top four images) or simultaneously (bottom four images). The total amount of time each stimulus appeared was constant. Subjects either performed an attentionally demanding task or attended to one of the four stimuli.

(B) fMRI signals. In area V1 (top images), where receptive fields are too small to include more than one stimulus, the presence of additional stimuli did not suppress neuronal responses, and attention had very little effect. However, in area V4 (bottom images), whose receptive fields are large enough to include multiple stimuli, presenting the stimuli simultaneously caused a suppressed response. This is illustrated in the reduced magnitude of the two middle peaks (labeled "SIM SIM") in the lower left image. When attention was directed to one of the stimuli (lower right image, time period labeled in blue), this suppression was largely filtered out.

experiments in humans support the idea of attentional modulation of an underlying sensory competition. Kastner et al. (1998) compared the average fMRI signal elicited by a stimulus when it was presented alone versus the signal elicited when the same stimulus appeared simultaneously with other stimuli (Figure 4A). They found that when attention was directed away to another location, the presence of the additional stimuli reduced the strength of the fMRI signal in the human analogs of monkey V4 and TEO, areas whose receptive fields are large enough to encompass multiple stimuli (Figure 4B). This suppressive effect was minimized when stimuli were separated from one another in space, consistent with the idea that competition is greatest for stimuli

occupying the same receptive field. Suppression was weakest in primary visual cortex, whose smaller receptive fields would rarely be expected to process information from more than one of the stimuli, resulting in minimal interactions between stimuli. When subjects were instructed to attend to stimuli at one of the locations, this eliminated most of the suppressive effect of the distractor stimuli, consistent with the physiological results in monkeys.

Evidence for the Attentional Bias

These experiments provide support for the idea that illusory conjunctions are resolved when attentional feedback signals bias an underlying competitive circuit, causing neurons to respond exclusively to the attended stimulus. Possibly the most direct physiological evidence for this predicted bias was reported by Luck et al. (1997a), who found that attending to a position within the receptive field of a neuron increased its spontaneous firing rate. The spontaneous activity of V2 and V4 neurons increased by 30%–40% when attention was directed to the location of the receptive field, even when the field contained no stimulus. A recent fMRI study in humans has found similar evidence for a sustained increase in activity with attention in the absence of visual stimulation, with the increases occurring at the retinotopic locus of the attended location in the visual field (Kastner et al., 1999). This effect was found in several cortical visual areas of the dorsal and ventral streams. In the physiological study of Luck et al. (1997a), the shift in firing rate was largest when the monkey attended to the “hot spot” of the receptive field, where stimuli elicited the strongest response, and was smallest when attention was directed toward the edge of the field. Thus, consistent with its putative role in selecting out one of several stimuli from within the receptive field, the attentional signal that gives rise to this change in spontaneous firing rate has a higher spatial resolution than the receptive field.

The bias in favor of an attended stimulus or location is also evidenced by an increase in response to a stimulus at an attended location, which has been found in many, but not all, physiological studies. With just a single stimulus inside the receptive field, Spitzer et al. (1988) found that when animals were required to perform an attentionally demanding task using that stimulus, responses of neurons in area V4 increased by 18%, compared to when the monkey’s attention was directed outside the field. More recently, Connor et al. (1996) have reported that V4 responses to stimuli appearing within the receptive field are sometimes enhanced when the monkey attends to a location just outside the receptive field. McAdams and Maunsell (1999) have found V4 responses to be increased by 26% when monkeys discriminated the orientation of a counterphase grating within the receptive field, as compared to the response elicited by the same stimulus when the monkey discriminated the color of a stimulus appearing outside the receptive field (Figure 5A).

Not all studies have found consistent enhancement of responses with attention to a single stimulus inside the receptive field, however. Moran and Desimone (1985), Haenny et al. (1988), Maunsell et al. (1991), Motter

(1993), and Luck et al. (1997a) have found either no effect of attention on the response to a single stimulus or changes in response that were nearly equally likely to be increases as decreases.

A possible explanation for this puzzle has recently been reported by Reynolds et al. (1996, *Soc. Neurosci.*, abstract; 1997, *Assoc. Res. Vis. Ophthalmol.*, abstract), who found that V4 neurons have increased contrast sensitivity when attention is directed to a position within the receptive field (Figure 5B). Neurons responded to faint attended stimuli that failed to elicit a response when attention was directed away from the receptive field. On average, attention caused cells to respond as though the luminance contrast of the stimulus had been increased by 22%. This increased sensitivity resulted in large increases in the neuronal response to low-contrast stimuli. The effect of attention to a single stimulus inside the receptive field was greatly reduced for high-contrast stimuli, which nearly saturated the neuronal response even in the absence of attention. Nicholas et al. (1996, *Soc. Neurosci.*, abstract) found that this increase in sensitivity was also reflected in enhanced responses to texture-defined stimuli. As with luminance contrast, the effect of attention to a single stimulus was diminished for texture-defined stimuli that were well segregated from their backgrounds. Together, the results indicate that although the bias in favor of an attended stimulus can easily be detected with stimuli that are low contrast, the effect of the bias may be missed if the response of the cells has already been saturated by highly salient stimuli that are easily discriminated from their backgrounds. Thus, variations in stimulus contrast, in addition to variations in task and task difficulty, may help explain the variability across studies in the effects of attention to single stimuli. One possible way of conceptualizing the effect of attention on single stimuli is illustrated in Figure 5C. Orientation tuning is largely invariant to changes in contrast (Skottun et al., 1987). For stimuli that are below saturation contrast, an increase in physical contrast will result in a gain multiplication of the orientation tuning curve. Similarly, a leftward shift of the contrast–response function resulting from increased neuronal sensitivity with attention also predicts a gain multiplication of the orientation tuning curve, which has been reported by McAdams and Maunsell (Figure 5C). Although they did not test stimuli across a range of contrasts in that study, the contrast used may have been below the saturation level of the cells.

Nonspatial Attention

In the cases considered above, attention was directed to a given location, and the features of the object at that location could be bound together by filtering unattended objects from the receptive fields of extrastriate neurons. How can attention solve the binding problem when the location of the object of interest is unknown in advance, e.g., when searching for a face in a crowd? In a recent study, Chelazzi et al. (1998) found that when monkeys search for an object in an array based on its features, this can modulate receptive fields of neurons in inferior temporal cortex in a manner similar to what happens in spatially directed attention (see Figure 6). In this task, monkeys viewed a cue stimulus, followed by a brief

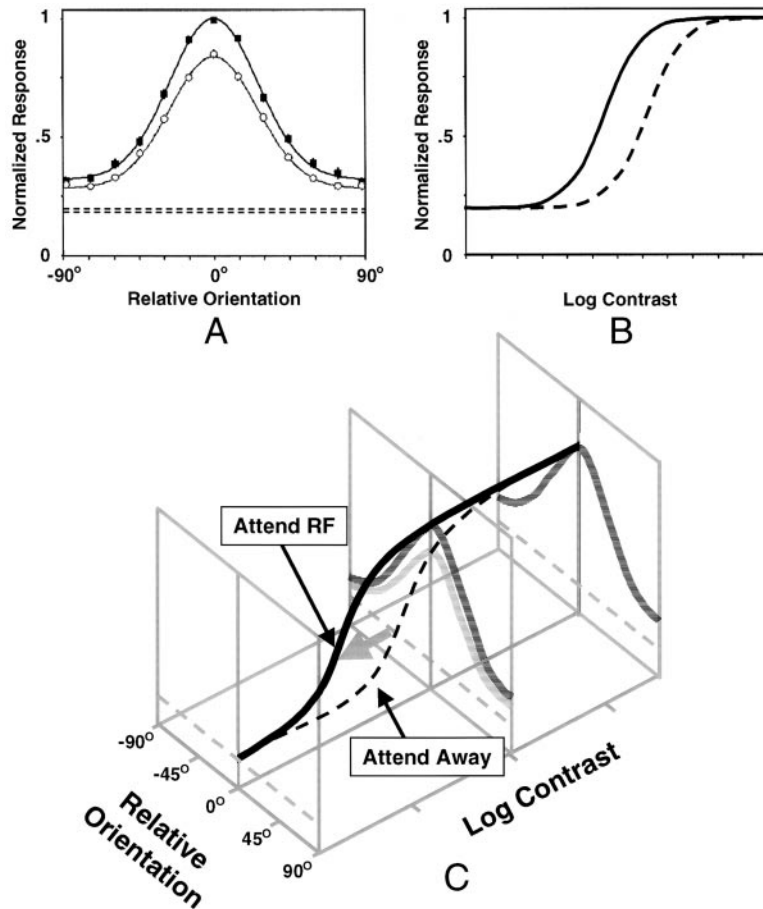

Figure 5. Gain Multiplication and Increased Sensitivity with Attention in Area V4

(A) McAdams and Maunsell (1999) found that attention caused a multiplicative increase in the orientation tuning curve.

(B) Reynolds et al (1996, Soc. Neurosci., abstract; 1997, Assoc. Res. Vis. Ophthalmol., abstract) found that attention caused an increase in V4 neurons' contrast sensitivity, as reflected in a leftward shift of the contrast-response function.

(C) A possible way to reconcile the two findings. The change in response resulting from changes in orientation and contrast are orthogonal. Thus, an increase in contrast sensitivity (leftward shift in the contrast-response function) will result in a multiplicative increase in the tuning curve.

delay, after which an array of stimuli (the *search array*) appeared within the neuron's receptive field. The monkeys' task was to indicate whether or not a target matching the cue stimulus was present in the array. The positions of the stimuli in the search array were selected at random, so the monkey could not know where the target would appear, if it appeared at all. During the delay period, many inferior temporal neurons had a higher baseline firing rate when the cue stimulus was a preferred stimulus for the cell than when it was a poor stimulus. This is analogous to the increase in baseline firing rates found in other studies when spatial attention was directed to a cell's receptive field (Luck et al., 1997a), and it is evidence for a bias in favor of neurons representing the target stimulus. Within 150–200 ms after the search array appeared, the neuron's response increased or decreased, depending on whether the cue was, respectively, a preferred or a poor stimulus for the cell. That is, shortly after the onset of the search array, the cell responded primarily to the target stimuli and responses to nontarget stimuli were suppressed. Thus, attention to an object feature apparently has effects on competitive interactions that are similar to those observed with attention to a spatial location.

Likely Sources of the Biasing Signal

Prefrontal and parietal cortex have a number of properties that implicate them as possible sources of task-dependant biasing signals in posterior visual areas. Pre-

frontal cortex shows elevated spontaneous responses that encode remembered spatial locations and remembered objects (Wilson et al., 1993; Rainer et al., 1998). It also has anatomical connections by which it could transmit these signals to appropriate dorsal and ventral stream areas (Barbas, 1988; Barbas and Pandya, 1989; Ungerleider et al., 1989). Parietal cortex also encodes remembered spatial locations in a form that could be read out as a spatial biasing signal and has the requisite anatomical connections to do so. Stimuli appearing at an attended location are preferentially represented in parietal cortex (Bushnell et al., 1981; Gottlieb et al., 1998), and different parts of parietal cortex provide a variety of different spatial reference frames that would be helpful in directing attentional feedback signals to behaviorally relevant locations in space (reviewed by Andersen, 1997; Colby and Goldberg, 1999). Patients with bilateral parietal lesions have difficulty binding together object features, despite the fact that these features are known to be processed primarily outside of parietal cortex. This would be expected from a lesion that eliminates an important source of signals that bias competitive interactions within the cortical areas that encode these features. Consistent with this, recent fMRI studies (Corbetta et al., 1993, 1995; Nobre et al., 1997; Kastner et al., 1999) have also found the superior parietal lobule in the human to be highly active during a spatial attention task.

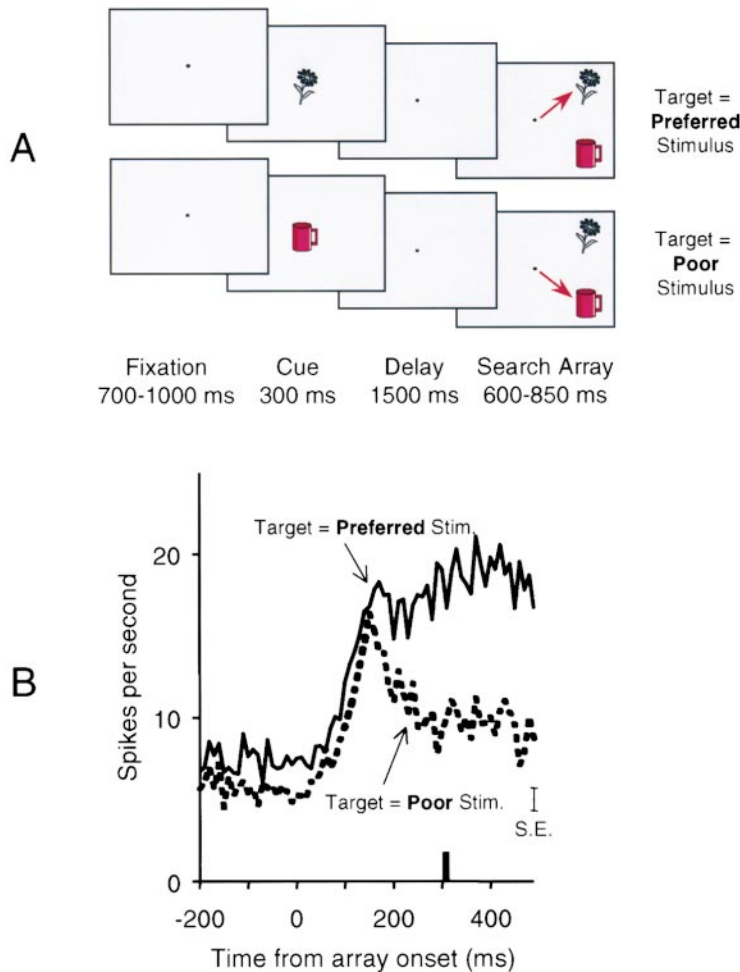

Figure 6. Responses of IT Neurons during Memory-Guided Search

(A) Task. Monkeys fixated a spot on a computer screen and were shown a central cue (here, either the flower or the cup). After a delay, two (or more) stimuli appeared within the receptive field, and the monkey had to saccade to the stimulus that had appeared earlier as the cue. Sometimes (top four images), the cue was a preferred stimulus for the cell (the flower) and the monkey had to saccade to the flower. On separate trials (lower four images), the cue was a poor stimulus (the cup) and the monkey had to saccade to the cup.

(B) Neuronal responses. During the delay period, IT neurons showed an elevated baseline activity that reflected the cue stored in memory. The spontaneous rate was higher on trials in which the cue was a preferred stimulus for the cell, relative to trials when the cue was a poor stimulus. After the search array appeared, the response separated, increasing or decreasing depending on whether the cue was, respectively, a preferred or poor stimulus for the cell. This separation occurred well before the onset of the saccade, which is indicated by the vertical bar on the horizontal axis.

Stimulus Salience Helps Ameliorate the Binding Problem

The picture that emerges from these considerations is that attentional feedback from areas such as prefrontal and parietal cortex eliminates illusory conjunctions by biasing competition in favor of stimuli appearing at the attended location or in favor of the searched-for object. The finding that attention causes extrastriate neurons to respond as though the salience of the stimulus had been increased (Nicholas et al., 1996, *Soc. Neurosci.*, abstract; Reynolds et al., 1996, *Soc. Neurosci.*, abstract; 1997, *Assoc. Res. Vis. Ophthalmol.*, abstract; Gottlieb et al., 1998) raises the intriguing possibility that physical salience itself may also play a part in resolving the binding problem. If high salience biases the same competitive mechanisms as does attention, this should cause neurons to "lock on to" whatever stimulus is most salient. This could partially ameliorate the binding problem for unattended stimuli by setting the visual system to bind together the features of the most salient stimulus by default. That is, when attention is not actively engaged in processing a stimulus within the scene, or when attention is directed away from the receptive field, the most salient element in the scene might dominate neuronal responses.

A recent experiment of Reynolds and Desimone (1997,

Soc. Neurosci., abstract) supports this hypothesis. We reasoned that if salience acts as a bottom-up bias on the same competitive mechanisms that appear to subserve attentional selection, then neuronal responses to a pair of stimuli should be dominated by the most salient stimulus within the receptive field. To test this, two stimuli were presented within the receptive fields of V4 neurons, while the monkey attended away to a location outside the receptive field. We varied the relative contrast of the two stimuli and compared the response elicited by the pair to the responses elicited by the two stimuli presented individually. The neuron's response to the pair was similar to its response to the higher-contrast stimulus presented alone. That is, the cell responded as though the low-contrast stimulus were not present. This result was most striking for highly selective cells, where increasing the contrast of the poorer stimulus significantly reduced the response to the pair, despite the fact that the poor stimulus alone elicited a small excitatory response. Consistent with the hypothesis that attention and high salience bias the same competitive mechanisms, the two effects were additive. When the monkey directed its attention to the higher-contrast stimulus, the neuron's response was independent of the presence of the lower-contrast, unattended stimulus. Thus, normal variations of salience in the visual environment may

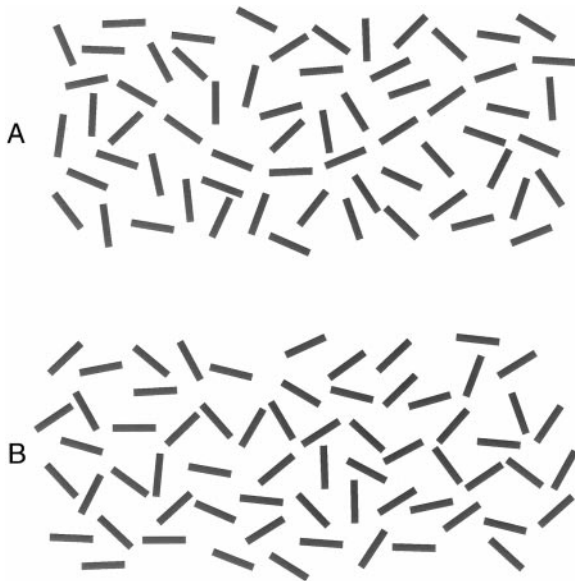

Figure 7. Saliency Can Emerge from Grouping
(A) A contour of nearly collinear line elements pops out of a background composed of randomly oriented line elements.
(B) If the elements connecting end-to-end are not roughly collinear, they do not form a salient grouping.

serve to partially ameliorate the binding problem even for unattended objects, by transferring control over neuronal responses to the most salient elements of the scene.

Clearly, this is only a partial solution to the general binding problem. Almost all physiological studies to date have used well-isolated, simple stimuli that could be segregated out from the background on the basis of changes in local luminance contrast. This leaves unresolved the difficult question of what actually competes for processing—is it local luminous flux, higher-order object features, or entire integrated “objects”? This difficult aspect of the binding problem remains unresolved, but studies of perceptual grouping suggest one way in which grouping principles could play a role. When individual elements form a perceptual group, they gain saliency and stand out from their background, as illustrated in Figure 7. In the upper panel, line elements that are roughly collinear cohere into a contour that stands out from the background, like a snake in the grass. The lower panel also includes a set of elements that connect end-to-end, but this grouping does not pop out because the elements are not collinear.

Kapadia et al. (1995) found an analogous effect of grouping on the responses of neurons in striate cortex. When a line element within the receptive field is presented together with additional, collinear elements outside the receptive field, the responses of many striate neurons are enhanced. Changing the spatial relationships between elements in ways that break up this perceptual group (such as introducing an intervening perpendicular element, separating the elements, or making them noncollinear) reduces or eliminates this enhancement. Saliency from perceptual grouping, represented by increased responses of neurons in striate cortex, is

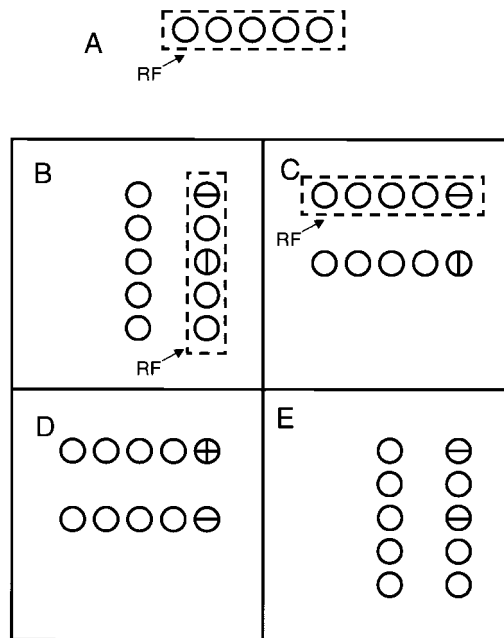

Figure 8. A Speculative Hypothesis about Illusory Conjunctions and Perceptual Grouping

(A) Suppose that when elements form a perceptual group, such as this row of stimuli, receptive fields shrink around the group.
(B) According to this hypothesis, the vertical and horizontal line elements fall within common receptive fields. As a result, neuronal response will be invariant across positions within the group, and the features may be misconjoined to form a plus.
(C) When the two elements appear within separate groups, we assume that they will not fall within a common receptive field and will not be misconjoined. Prinzmetal (1981) found that illusory conjunctions are more likely among elements within a group than among elements in separate groups.
(D and E) Control conditions in which illusory conjunctions cannot occur because the plus is actually present (D) or because the two features were of the same orientation (E).

likely to influence higher-order extrastriate neurons in much the same way as saliency arising directly from high luminance contrast and texture popout. It remains to be seen whether perceptual groups defined by factors such as collinearity, closure, similarity, symmetry, proximity, common motion, and common onset will turn out to have enhanced control over neuronal responses in higher-order areas with large receptive fields.

This is clearly a speculative hypothesis, but it does make an interesting prediction. We have presented evidence that illusory conjunctions emerge as a result of the spatial uncertainty that results from the large receptive fields found in extrastriate cortex. If, as a result of the more salient representation of groups in earlier cortical areas, higher-order extrastriate receptive fields effectively shrink around perceptual groups (see Figure 8A), this would separate elements from different groups into separate receptive fields. Illusory conjunctions should therefore be more likely between features appearing within a perceptual group than between equally spaced features appearing in separate perceptual groups.

This is exactly what was found in a study conducted by Prinzmetal (1981). Arrays of circles appeared briefly,

followed by a mask. They were either arranged to form two columns (as in Figure 8B) or two rows (as in Figure 8C). The arrays typically included a vertical and a horizontal line segment, either appearing at the same location, to form a plus (as in Figure 8D), or appearing at separate locations (as in Figures 8B and 8C). The two line segments could either appear within the same perceptual group (as in Figure 8B) or in separate groups (as in Figure 8C). Prinzmetal measured how often subjects misconjoined the vertical and horizontal line segments to form an illusory plus. In a comparison condition (see Figure 8E), the two line segments were of the same orientation, so they could not form an illusory conjunction. Subjects often incorrectly reported seeing a plus symbol when the line segments were perpendicular to one another. Despite the fact that the physical separation of the two line segments was identical, subjects were significantly more likely to form illusory conjunctions between elements within a perceptual group than when they appeared within separate groups.

As described earlier, sensory interactions and attention effects are greatest when two stimuli appear within a common receptive field. This provides a way to probe the hypothesis that receptive fields shrink around salient perceptual groups. It will be interesting to see whether competitive sensory interactions and associated attentional modulations will turn out to be greater among elements within a perceptual group than among elements in separate groups.

Biological Constraints on Models

The results reviewed above provide several constraints on models of the circuitry underlying attentive visual processing, and hence provide insight into some of the neural mechanisms involved in solving the binding problem. First, with attention directed away from the receptive field, the effect of adding a second stimulus inside the receptive field is to draw the neuron's response toward the response elicited by the added stimulus alone. If we change the identity of the second stimulus so that it elicits a smaller response when presented alone, it typically becomes proportionally more suppressive.

Second, neuronal responses are biased toward the more salient stimulus. If a preferred stimulus is paired with a poor excitatory stimulus, the suppression caused by adding the poor stimulus typically increases with the contrast of the poor stimulus.

Third, when attention is directed to a location within the receptive field, this increases the neuron's sensitivity to stimuli appearing at that location, as reflected in the cell's ability to respond to low-salience stimuli that do not elicit a response when unattended.

Fourth, when multiple stimuli appear together, attending to one of them causes the neuronal response to be biased toward the response that would have been elicited if the attended stimulus had appeared alone. Thus, attending to the poorer of two stimuli typically reduces the neuronal response to the pair.

Fifth, the control bias arising from differences in relative salience adds to the bias arising from attentional

feedback. Directing attention to a higher-contrast stimulus causes it to exert even greater control over the neuronal response, while attending to the lower-contrast stimulus counteracts the relative contrast bias. This enables the neuron to respond to an attended low-contrast stimulus, even in the presence of a high-contrast distractor.

Sixth, attention has the capacity to modulate the responses of neurons at a spatial scale that is smaller than the scale of an individual receptive field. When multiple stimuli appear within the receptive field, attention causes the neuron to selectively process one stimulus within the receptive field while filtering out others. This high spatial resolution is also reflected in the attentionally induced increases in spontaneous firing rate, which vary in magnitude as a function of precisely where in the receptive field attention is directed.

Seventh, the effect of attention depends on spatial separation of stimuli. Two stimuli can be placed far enough apart that they will fall within separate receptive fields in one cortical area, say V2, while remaining close enough together to fall within a common receptive field at a subsequent area. Here, the effect of attention changes from simple enhancement to a shift of control, as illustrated in Figure 9. Thus, at one stage, attention serves to boost the strength of the stimulus-evoked response, separating it from one form of noise: spontaneous activity. At the subsequent stage, attention filters out a second type of noise: the signal that is elicited by the unattended stimulus.

A Model Based on Biased Competition

One possible model that satisfies these constraints is illustrated in Figure 10. The model assumes that when two stimuli appear within the visual field, they will, at some stage of cortical processing, activate separate populations of neurons. The two circles at the bottom of the figure represent these two input populations. The circuit is assumed to be repeated at each stage of the cortical hierarchy, but to fix ideas, let us suppose these input populations are in area V2. If the stimuli appear close enough to one another, they will activate input populations that project to a common output neuron in the subsequent stage of cortical processing (say, V4). The circle at the top of the figure is intended to represent this output neuron. Each input population is assumed to provide both excitatory and inhibitory drive to the output neuron, through inhibitory interneurons, which are not shown in the figure. The response of the output neuron is assumed to depend on the ratio of excitatory to inhibitory drive from the input populations. The selectivity of the output neuron for the two stimuli therefore depends on the strength of excitatory and inhibitory inputs projecting from each input population. The stimulus whose input population provides proportionally more excitatory input will elicit a relatively stronger response in the output neuron.

The model accounts for the observed relationships between selectivity, sensory interactions, and attention effects, as follows. When the two stimuli appear together, their excitatory inputs are assumed to be additive, as are their inhibitory inputs. Therefore, when a second stimulus is added to the receptive field, the output neuron's response will shift toward the response

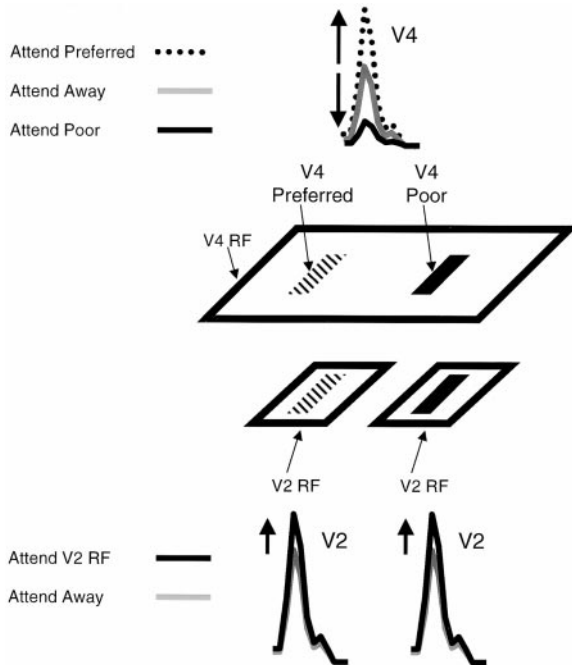

Figure 9. Dependence of Attentional Modulation on Receptive Field Size

A qualitative change in the effect of attention takes place when information passes from a cortical area with receptive fields too small to include both stimuli to a successive cortical area with receptive fields that are large enough to encompass both stimuli. At the bottom of the figure, we show the schematic responses of two neurons in an area with small receptive fields. The hatched stimulus on the left falls within the receptive field of the neuron whose response is illustrated on the left. The solid stimulus on the right falls within the receptive field of the other neuron, on the right. For both of these hypothetical neurons, the response is magnified when attention is directed toward the stimulus within the receptive field. The larger box above illustrates the larger receptive field of a higher-order neuron. Here, the two stimuli fall within a common receptive field. When attention is directed to the cell's preferred stimulus (the hatched bar), this causes an increase in response. However, when attention is directed to the poor stimulus, this results in a reduced response.

elicited by the second stimulus alone, as observed experimentally. If the physical salience of one of the stimuli is increased, this is assumed to increase the magnitude of the response elicited in the input population, and the output neuron's response will shift toward the response that would be elicited by the more salient stimulus alone. Attention is assumed to act in an analogous manner, by increasing the efficacy of synapses projecting from the neuronal population activated by the attended stimulus. Thus, attention will increase contrast sensitivity at the attended location. This change of synaptic efficacy will also increase the output neuron's sensitivity to spontaneous activity of afferent neurons, resulting in a baseline shift. The spatial selectivity of this baseline shift follows from the spatial specificity of the projections from afferent neurons to the output neuron. The model accounts for the finding that attention effects are minimal for high-contrast stimuli, because at high contrast the response of the output neuron is already saturated by strong excitatory and inhibitory inputs, and further increases of input strength will not cause further increases in response.

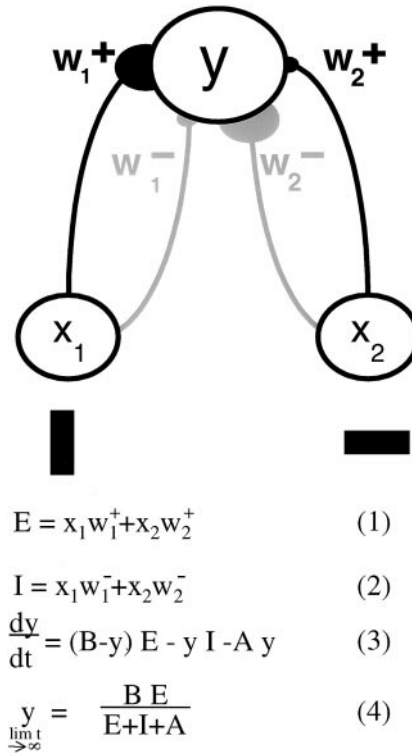

Figure 10. One Possible Implementation of the Biased Competition Model

The circle on top represents the neuron being recorded, whose firing rate is designated by the variable y . The two circles below represent populations of "input" neurons that respond to the reference and probe stimuli, respectively, and that project to the upper neuron. The average responses of the input populations are designated x_1 and x_2 . Black lines represent the excitatory projections from each input population to the measured cell, and gray lines indicate the inhibitory projections, which are assumed to depend on inhibitory interneurons (not shown in figure). The variables w_1^+ and w_2^+ stand for the magnitudes, or weights, of the excitatory projections from the two input populations, while w_1^- and w_2^- stand for the weights of the inhibitory projections. Equations 1 and 2 state, respectively, that the total excitatory and inhibitory inputs to the cell are the responses of the input populations, weighted, respectively, by their excitatory and inhibitory weights. Equation 3 describes the change in the response of the output neuron over time. Equation 4 describes the equilibrium response of the output neuron, which depends on the total mix of excitatory and inhibitory input. The model is further described in Reynolds et al. (1999).

The effect of attention is unmasked by the presence of a second stimulus inside the receptive field because attention must now filter out the large signals elicited by the competing stimulus. Increasing the efficacy of inputs from the attended population causes the mix of excitatory and inhibitory inputs, and thus the output neuron response, to be dominated by the attended stimulus. Input strength can be adjusted by either a change in synaptic efficacy or a change in the strength of response in the input population, so the effects of attention and relative contrast are additive. The high spatial resolution of attentional modulation arises because the input neurons, whose synapses are assumed to be modulated by attention, have the requisite fine spatial resolution. When the two stimuli appear together so that they both

appear within the receptive field, a change in the efficacy of synapses projecting from one input population will filter the nonattended stimulus out of the V4 receptive field.

The biased competition model provides a unified framework within which to think about attention and its role in resolving the binding problem. However, the implementation sketched above is only one of a number of possible models that satisfy the constraints derived from the neurophysiological literature on attention. Among the existing alternatives are models that implement competitive interactions using lateral inhibitory connections and assume that the attentional bias is mediated by a direct excitatory signal or by triggering synchronous discharge among cells whose receptive fields overlap with the focus of attention (see, e.g., Koch and Ullman, 1985; Anderson and Van Essen, 1987; Niebur et al., 1993; Olshausen et al., 1993; Ferrera and Lisberger, 1995; Grossberg, 1995, 1999a, 1999b; Stemmler et al., 1995; Pouget and Sejnowski, 1997; Borisjuk et al., 1998). Additional experiments will be necessary to further constrain the set of possible models.

Relationship between Our Proposal and Other Theories of Illusory Conjunctions

The explanation we have proposed for the role of attention in resolving illusory conjunctions is related to the Feature Integration Theory (FIT) proposed by Treisman and Gelade (1980) (see also Treisman and Schmidt, 1982; Treisman, 1996). Like FIT, our explanation depends on the proposition that illusory conjunctions arise from the decomposition of visual stimuli into their constituent features and that attention is necessary to avoid illusory conjunctions of the features.

Our proposal differs from FIT in several ways. First, we propose that illusory conjunctions arise specifically because of the spatial uncertainty that results from the large receptive fields found in higher-order visual areas, and that attention resolves this uncertainty by biasing competitive cortical mechanisms in favor of the attended stimulus. This proposal is similar in spirit to the Ambiguity Resolution Theory proposed by Luck et al. (1997b). In addition, our proposal is that attentional feedback is only one of many factors that can bias competition in favor of a particular object. We predict that other factors, such as variation in the relative salience of stimuli, which also bias competition, can reduce or eliminate illusory conjunctions. As demonstrated by Chelazzi et al. (1998), working memory can also bias competitive interactions in a way analogous to spatial attention. This could be crucial in avoiding illusory conjunctions between overlapping objects, where spatial attention alone cannot, in principle, link features together correctly. Our model offers a way to explain how a spatially distributed perceptual group of elements may be linked together into a whole and segregated out from its background, by making use of the greater salience of grouped elements to put the grouped elements at a competitive advantage over ungrouped elements. Finally, because our model is implemented at the neuronal level, it offers a way to bridge the gap between the psychophysics and neurophysiology of attention.

Conclusions

Findings from neurophysiology, psychophysics, and fMRI all converge on a common conclusion about the role of attention in solving one aspect of the binding problem: illusory conjunctions. When multiple unattended stimuli appear within the receptive field of an extrastriate neuron, the neuronal response cannot unambiguously be associated with any one stimulus, and it is this ambiguity that leads to illusory conjunctions. Attentional mechanisms eliminate illusory conjunctions by filtering out unattended stimuli whose features could be misconjoined with those of the attended stimulus.

This selection process occurs in several stages and depends on attentionally induced increases in the effective salience of the attended object in earlier stages of processing, where it appears alone within a receptive field. As signals from multiple stimuli progress forward into higher-order areas with larger receptive fields, stimuli compete to control neuronal responses. The added strength of the signals from the attended stimulus resolves this competition in its favor. As a result, the responses of higher-order neurons with large receptive fields encode only the attended stimulus, implicitly binding together its features. In the absence of attentional control, a highly salient stimulus (e.g., based on higher luminance or perceptual grouping principles) may also bias the same competitive mechanisms, helping to resolve illusory conjunctions among unattended objects. Finally, all of these mechanisms for attentional selection and salience operate in concert within multiple cortical areas of dorsal and ventral visual processing streams, implicitly binding together the features encoded by different neurons throughout extrastriate cortex.

Acknowledgments

We thank L. Chelazzi, V. Ferrera, P. Fries, S. Kastner, and A. Rossi for helpful comments on the manuscript.

References

A comprehensive reference list for all reviews can be found on pages 111–125.

References for Reviews on the Binding Problem

- Abeles, M. (1982a). Role of cortical neuron: integrator or coincidence detector? *Israel J. Med. Sci.* *18*, 83–92.
- Abeles, M. (1982b). *Studies of Brain Function, Volume 6, Local Cortical Circuits: An Electrophysiological Study* (Berlin: Springer-Verlag).
- Abeles, M. (1991). *Corticomics: Neural Circuits of Cerebral Cortex* (Cambridge: Cambridge University Press).
- Abeles, M., Prut, Y., Bergman, H., and Vaadia, E. (1994). Synchronization in neuronal transmission and its importance for information processing. *Prog. Brain Res.* *102*, 395–404.
- Adam, H. (1998). *Figur-Grund-Abtrennung mit rückgekoppelten Merkmalsfeldern*. PhD Thesis, Department of Physics and Astronomy, Ruhr University, Bochum, Germany.
- Adelson, E.H. (1993). Perceptual organization and the judgment of brightness. *Science* *262*, 2042–2044.
- Adelson, E.H. (1999). Lightness perception and lightness illusions. In *The Cognitive Neurosciences*, M.S. Gazzaniga, ed. (Cambridge, MA: MIT Press).
- Adelson, E.H., and Movshon, J.A. (1982). Phenomenal coherence of moving visual patterns. *Nature* *300*, 523–525.
- Aertsen, A., Gerstein, G.L., Habib, M.K., and Palm, G. (1989). Dynamics of neuronal firing correlation: modulation of “effective connectivity.” *J. Neurophysiol.* *61*, 900–917.
- Aertsen, A., Diesmann, M., and Gewaltig, M.-O. (1996). Propagation of synchronous spiking activity in feedforward neural networks. *J. Physiol. (Paris)* *90*, 243–247.
- Aiple, F., and Krüger, J. (1988). Neuronal synchrony in monkey striate cortex: interocular signal flow and dependency on spike rates. *Exp. Brain Res.* *72*, 141–149.
- Alais, D., Blake, R., and Lee, S.-H. (1998). Visual features that vary together over time group together over space. *Nat. Neurosci.* *1*, 160–164.
- Albright, T.D., and Stoner, G.R. (1995). Visual motion perception. *Proc. Natl. Acad. Sci. USA* *92*, 2433–2440.
- Alonso, J.-M., and Martinez, L.M. (1998). Functional connectivity between simple cells and complex cells in cat striate cortex. *Nat. Neurosci.* *1*, 395–403.
- Alonso, J.-M., Usrey, W.M., and Reid, R.C. (1996). Precisely correlated firing in cells of the lateral geniculate nucleus. *Nature* *383*, 815–819.
- Andersen, R.A. (1995). Encoding of intention and spatial location in the posterior parietal cortex. *Cereb. Cortex* *5*, 457–469.
- Andersen, R.A. (1997). Multimodal integration for the representation of space in the posterior parietal cortex. *Philos. Trans. R. Soc. Lond. B Biol. Sci.* *352*, 1421–1428.
- Anderson, C.H., and Van Essen, D.C. (1987). Shifter circuits: a computational strategy for dynamic aspects of visual processing. *Proc. Natl. Acad. Sci. USA* *84*, 6297–6301.
- Arbib, M. (1964). *Brains, Machines and Mathematics* (New York: McGraw-Hill).
- Arguin, M., Cavanagh, P., and Joannette, Y. (1994). Visual feature integration with an attention deficit. *Brain Cogn.* *24*, 44–56.
- Arieli, A., Sterkin, A., Grinvald, A., and Aertsen, A. (1996). Dynamics of ongoing activity: explanation of the large variability in evoked cortical responses. *Science* *273*, 1868–1871.
- Ashby, F.G., Prinzmetal, W., Ivry, R., and Maddox, W.T. (1996). A formal theory of feature binding in object perception. *Psychol. Rev.* *103*, 165–192.
- Assad, J., and Maunsell, J. (1995). Neuronal correlates of inferred motion in primate posterior parietal cortex. *Nature* *373*, 518–521.
- Bair, W. (1999). Spike timing in the mammalian visual system. *Curr Opin. Neurobiol.*, in press.
- Bair, W. and Koch, C. (1995). Precision and reliability of neocortical spike trains in the behaving monkey. In *The Neurobiology of Computation*, B.J. Kluwer, ed. (New York: Academic Publishers).
- Bair, W., and Koch, C. (1996). Temporal precision of spike trains in extrastriate cortex of the behaving monkey. *Neural Comput.* *8*, 44–66.
- Bair, W., and O’Keefe, L.P. (1998). The influence of fixational eye movements on the response of neurons in area MT of the macaque. *Vis. Neurosci.* *15*, 779–786.
- Bair, W., Koch, C., Newsome, W., and Britten, K. (1994). Power spectrum analysis of bursting cells in area MT in the behaving monkey. *J. Neurosci.* *14*, 2870–2892.
- Bair, W., Cavanaugh, J.R., and Movshon, J.A. (1997). Reconstructing stimulus velocity from neuronal responses in area MT. In *Advances in Neural Information Processing Systems*, M.C. Mozer, M.I. Jordan, and T. Petsche, eds. (Cambridge, MA: MIT Press).
- Baldi, P., and Meir, R. (1990). Computing with arrays of coupled oscillators: an application to preattentive texture discrimination. *Neural Comput.* *2*, 458–471.
- Ballard, D.H., Hinton, G.E., and Sejnowski, T.J. (1983). Parallel visual computation. *Nature* *306*, 21–26.
- Barbas, H. (1988). Anatomic organization of basoventral and medio-dorsal visual recipient prefrontal regions in the rhesus monkey. *J. Comp. Neurol.* *276*, 313–342.
- Barbas, H., and Pandya, D.N. (1989). Architecture and intrinsic connections of the prefrontal cortex in the rhesus monkey. *J. Comp. Neurol.* *286*, 353–375.
- Barlow, H.B. (1972). Single units and cognition: a neurone doctrine for perceptual psychology. *Perception* *1*, 371–394.
- Barlow, H.B. (1981). Critical limiting factors in the design of the eye and visual cortex. *Proc. R. Soc. Lond. B Biol. Sci.* *212*, 1–34.
- Barlow, H.B. (1985). The twelfth Bartlett memorial lecture: the role of single neurons in the psychology of perception. *Quart. J. Exp. Psychol.* *37*, 121–145.
- Bauer, H.-U., and Pawelzik, K. (1993). Alternating oscillatory and stochastic dynamics in a model for a neuronal assembly. *Physica D69*, 380–393.
- Baylis, G.C., Rolls, E.T., and Leonard, C.M. (1985). Selectivity between faces in the responses of a population of neurons in the cortex in the superior temporal sulcus of the monkey. *Brain Res.* *342*, 91–102.
- Baylis, G.C., Rolls, E.T., and Leonard, C.M. (1987). Functional subdivisions of the temporal lobe neocortex. *J. Neurosci.* *7*, 330–342.
- Beck, J. (1966). Perceptual grouping produced by changes in orientation and shape. *Science* *154*, 538–540.
- Beck, J. (1967). Perceptual grouping produced by line figures. *Percept. Psychophys.* *2*, 491–495.
- Behrmann, M., and Tipper, S.P. (1994). Object-based attentional mechanisms: evidence from patients with unilateral neglect. In *Attention and Performance, Volume 15, Conscious and Nonconscious Information Processing*, C. Umiltà and M. Moscovitch, eds. (Cambridge, MA: MIT Press).
- Bergen, J.R., and Adelson, E.H. (1988). Early vision and texture perception. *Nature* *333*, 363–364.
- Bergen, J.R., and Julesz, B. (1983). Parallel versus serial processing in rapid pattern discrimination. *Nature* *303*, 696–698.
- Best, J., Reuss, S., and Dinse, H.R.O. (1986). Lamina-specific differences of visual latencies following photic stimulation in the cat striate cortex. *Brain Res.* *385*, 356–360.
- Biederman, I. (1981). On the semantics of a glance at a scene. In *Perceptual Organization*, M. Kubovy and J. Pomerantz, eds. (Hillsdale, NJ: Lawrence Erlbaum Associates).
- Biederman, I. (1987). Recognition by components: A theory of human image understanding. *Psychol. Rev.* *94*, 115–147.
- Biederman, I. and Kalocsai, P. (1997). Neurocomputational bases of object and face recognition. *Philos. Trans. R. Soc. Lond. B Biol. Sci.* *352*, 1203–1219.
- Bienenstock, E. (1995). A model of neocortex. *Network* *6*, 179–224.

- Bienenstock, E., and von der Malsburg, C. (1987). A neural network for invariant pattern recognition. *Europhys. Lett.* **4**, 121–126.
- Blake, R., and Yang, Y. (1997). Spatial and temporal coherence in perceptual binding. *Proc. Natl. Acad. Sci. USA* **94**, 7115–7119.
- Booth, M., and Rolls, E. (1998). View-invariant representations of familiar objects by neurons in the inferior temporal visual cortex. *Cereb. Cortex* **8**, 510–523.
- Borg-Graham, L., Monier, C., and Fregnac, Y. (1996). Voltage-clamp measurement of visually-evoked conductances with whole-cell patch recordings in primary visual cortex. *J. Physiol. (Paris)* **90**, 185–188.
- Borg-Graham, L.J., Monier, C., and Fregnac, Y. (1998). Visual input evokes transient and strong shunting inhibition in visual cortical neurons. *Nature* **393**, 369–373.
- Borisyuk, R.M., Borisyuk, G.N., and Kazanovich, Y.B. (1998). The synchronization principle in modelling of binding and attention. *Membr. Cell Biol.* **11**, 753–761.
- Bosking, W.H., Zhang, Y., Schofield, B., and Fitzpatrick, D. (1997). Orientation selectivity and the arrangement of horizontal connections in tree shrew striate cortex. *J. Neurosci.* **17**, 2112–2127.
- Boussaoud, D., Ungerleider, L.G., and Desimone, R. (1990). Pathways for motion analysis: cortical connections of the medial superior temporal and fundus of the superior temporal visual area in the macaque. *J. Comp. Neurol.* **296**, 462–495.
- Bouyer, J.J., Montaron, M.F., and Rougeul, A. (1981). Fast frontoparietal rhythms during combined focused attentive behaviour and immobility in cat: cortical and thalamic localizations. *Electroencephalogr. Clin. Neurophysiol.* **51**, 244–252.
- Bradley, D.C., Chang, G.C., and Andersen, R.A. (1998). Encoding of three-dimensional structure-from-motion by primate area MT neurons. *Nature* **392**, 714–717.
- Bragin, A., Jando, G., Nadasdy, Z., Hetke, J., Wise, K., and Buzsaki, G. (1995). Gamma (40–100 Hz) oscillation in the hippocampus of the behaving rat. *J. Neurosci.* **15**, 47–60.
- Braitenberg, V. (1978). Cell assemblies in the cerebral cortex. In *Lecture Notes in Biomathematics, Volume 21, Theoretical Approaches in Complex Systems*, R. Heim and G. Palm, eds. (Berlin: Springer).
- Braitenberg, V., and Schuz, A. (1991). *Anatomy of the Cortex: Statistics and Geometry* (Berlin: Springer).
- Braun, J., and Julesz, B. (1998). Dividing attention at little cost: detection and discrimination tasks. *Percept. Psychophys.* **60**, 1–23.
- Bravo, M., and Blake, R. (1990). Preattentive vision and perceptual groups. *Perception* **19**, 515–522.
- Brecht, M., Singer, W., and Engel, A.K. (1998). Correlation analysis of corticotectal interactions in the cat visual system. *J. Neurophysiol.* **79**, 2394–2407.
- Bressler, S.L., Coppola, R., and Nakamura, R. (1993). Episodic multi-regional cortical coherence at multiple frequencies during visual task performance. *Nature* **366**, 153–156.
- Briand, K.A., and Klein, R.M. (1987). Is Posner's "beam" the same as Triesman's "glue"? On the relation between visual orienting and feature integration theory. *J. Exp. Psychol. Hum. Percept. Perform.* **13**, 228–241.
- Britten, K.H., Shadlen, M.N., Newsome, W.T., and Movshon, J.A. (1992). The analysis of visual motion: a comparison of neuronal and psychophysical performance. *J. Neurosci.* **12**, 4745–4765.
- Britten, K.H., Newsome, W.T., Shadlen, M.N., Celebrini, S., and Movshon, J.A. (1996). A relationship between behavioral choice and the visual responses of neurons in macaque MT. *Vis. Neurosci.* **13**, 87–100.
- Brody, C.D. (1998). Slow covariations in neuronal resting potentials can lead to artefactually fast cross-correlations in their spike trains. *J. Neurophysiol.* **80**, 3345–3351.
- Brody, C.D. (1999a). Disambiguating different covariation types. *Neural Comput.* **11**, 1527–1535.
- Brody, C.D. (1999b). Correlations without synchrony. *Neural Comput.* **11**, 1537–1551.
- Brody, C.D. (1999c). Latency, excitability, and spike timing covariations. *Neural Comput.*, in press.
- Bruce, C., Desimone, R., and Gross, C. (1981). Visual properties of neurons in a polysensory area in the superior temporal sulcus of the macaque. *J. Neurophysiol.* **46**, 369–384.
- Bülthoff, H., and Edelman, S. (1992). Psychophysical support for a two-dimensional view interpolation theory of object recognition. *Proc. Natl. Acad. Sci. USA* **89**, 60–64.
- Bülthoff, H.H., Edelman, S.Y., and Tarr, M.J. (1995). How are three-dimensional objects represented in the brain? *Cereb. Cortex* **3**, 247–260.
- Buračas, G., Zador, A., DeWeese, M., and Albright, T. (1998). Efficient discrimination of temporal patterns by motion-sensitive neurons in primate visual cortex. *Neuron* **20**, 959–969.
- Burr, D. (1979). Acuity for apparent vernier offset. *Vision Res.* **19**, 835–837.
- Bush, P., and Sejnowski, T. (1996). Inhibition synchronizes sparsely connected cortical neurons within and between columns in realistic network models. *J. Comput. Neurosci.* **3**, 91–110.
- Bushnell, M.C., Goldberg, M.E., and Robinson, D.L. (1981). Behavioral enhancement of visual responses in monkey cerebral cortex. I. Modulation in posterior parietal cortex related to selective visual attention. *J. Neurophysiol.* **46**, 755–772.
- Buzsaki, G. (1996). The hippocampo-neocortical dialogue. *Cereb. Cortex* **6**, 81–92.
- Buzsaki, G., and Chrobak, J.J. (1995). Temporal structure in spatially organized neuronal ensembles: a role for interneuronal networks. *Curr. Opin. Neurobiol.* **5**, 504–510.
- Buzsaki, G., Leung, L.S., and Vanderwolf, C.H. (1983). Cellular basis of hippocampal EEG in the behaving rat. *Brain Res.* **6**, 139–171.
- Caminiti, R., Ferraina, S., and Johnson, P.B. (1996). The sources of visual information to the primate frontal lobe: a novel role for the superior parietal lobule. *Cereb. Cortex* **6**, 319–328.
- Carney, T., Paradiso, M., and Freeman, R. (1989). A physiological correlate of the Pulfrich effect in cortical neurons of the cat. *Vision Res.* **29**, 155–165.
- Carney, T., Silverstein, D., and Klein, S. (1995). Vernier acuity during image rotation and translation: visual performance limits. *Vision Res.* **35**, 1951–1964.
- Castelo-Branco, M., Neuenschwander, S., and Singer, W. (1998). Synchronization of visual responses between the cortex, lateral geniculate nucleus, and retina in the anesthetized cat. *J. Neurosci.* **18**, 6395–6410.
- Cave, K.R. (1999). The Feature Gate model of visual selection. *Psychol. Res.*, in press.
- Cave, K.R., and Bichot, N.P. (1999). Visuo-spatial attention: beyond a spotlight model. *Psychonom. Bull. Rev.*, in press.
- Cave, K.R., and Kosslyn, S.M. (1989). Varieties of size-specific visual selection. *J. Exp. Psychol. Gen.* **118**, 148–164.
- Cave, K.R., and Wolfe, J.M. (1990). Modeling the role of parallel processing in visual search. *Cogn. Psychol.* **22**, 225–271.
- Chance, F., Nelson, S., and Abbott, L. (1999). Complex cells as cortically amplified simple cells. *Nat. Neurosci.* **2**, 277–282.
- Chelazzi, L., Miller, E.K., Duncan, J., and Desimone, R.C. (1993). A neural basis for visual search in inferior temporal cortex. *Nature* **363**, 345–347.
- Chelazzi, L., Duncan, J., Miller, E.K., and Desimone, R. (1998). Responses of neurons in inferior temporal cortex during memory-guided visual search. *J. Neurophysiol.* **80**, 2918–2940.
- Cheng, K., Hasegawa, T., Saleem, K.S., and Tanaka, K. (1994). Comparison of neuronal selectivity for stimulus speed, length, and contrast in the prestriate visual cortex areas V4 and MT of the macaque monkey. *J. Neurophysiol.* **71**, 2269–2280.
- Chino, Y., Shansky, M., Jankowski, W., and Banser, F. (1983). Effects of rearing kittens with convergent strabismus on development of receptive-field properties in striate cortex neurons. *J. Neurophysiol.* **50**, 265–286.
- Chino, Y.M., Smith, E.L., Wada, H., Ridder, W.H., Langston, A.L., and Leshner, G.A. (1991). Disruption of binocularly correlated signals alters the postnatal development of spatial properties in cat striate cortical neurons. *J. Neurophysiol.* **65**, 841–859.

- Chrobak, J.J., and Buzsaki, G. (1998). Gamma oscillations in the entorhinal cortex of the freely behaving rat. *J. Neurosci.* *18*, 388–398.
- Churchland, P.S., Ramachandran, V.S., and Sejnowski, T.J. (1994). A critique of pure vision. In *Large-Scale Neuronal Theories of the Brain*, C. Koch and J.L. Davis, eds. (Cambridge, MA: MIT Press).
- Cobb, S.R., Buhl, E.H., Halasy, K., Paulsen, O., and Somogyi, P. (1995). Synchronization of neuronal activity in hippocampus by individual GABAergic interneurons. *Nature* *378*, 75–78.
- Cohen, A., and Ivry, R.B. (1989). Illusory conjunctions inside and outside the focus of attention. *J. Exp. Psychol. Hum. Percept. Perform.* *15*, 650–663.
- Cohen, A., and Ivry, R.B. (1991). Density effects in conjunction search: evidence for coarse location mechanism of feature integration. *J. Exp. Psychol. Hum. Percept. Perform.* *17*, 891–901.
- Colby, C.L., and Goldberg, M.E. (1999). Space and attention in parietal cortex. *Annu. Rev. Neurosci.* *22*, 319–349.
- Colby, C.L., Duhamel, J.-R., and Goldberg, M.E. (1996). Visual, presaccadic, and cognitive activation of single neurons in monkey lateral intraparietal area. *J. Neurophysiol.* *76*, 2841–2852.
- Connor, C.E., Gallant, J.L., Preddie, D.C., and Van Essen, D.C. (1996). Responses in area V4 depend on the spatial relationship between stimulus and attention. *J. Neurophysiol.* *75*, 1306–1308.
- Connor, C., Preddie, D., Gallant, J., and van Essen, D. (1997). Spatial attention effects in macaque area V4. *J. Neurosci.* *17*, 3201–3214.
- Connors, B.W., and Gutnick, M.J. (1990). Intrinsic firing patterns of diverse neocortical neurons. *Trends Neurosci.* *13*, 99–104.
- Connors, B.W., Gutnick, M.J., and Prince, D.A. (1982). Electrophysiological properties of neocortical neurons in vitro. *J. Neurophysiol.* *48*, 1302–1320.
- Corbetta, M., Miezin, F.M., Shulman, G.L., and Petersen, S.E. (1993). A PET study of visuospatial attention. *J. Neurosci.* *13*, 1202–1226.
- Corbetta, M., Shulman, G.L., Miezin, F.M., and Petersen, S.E. (1995). Superior parietal cortex activation during spatial attention shifts and visual feature conjunction. *Science* *270*, 802–805.
- Cowey, A., and Gross, C.G. (1970). Effects of foveal prestriate and inferotemporal lesions on visual discrimination by rhesus monkeys. *Exp. Brain Res.* *11*, 128–144.
- Creutzfeldt, O.D., Garey, L.J., Kuroda, R., and Wolff, J.R. (1977). The distribution of degenerating axons after small lesions in the intact and isolated visual cortex of the cat. *Exp. Brain Res.* *27*, 419–440.
- Crewther, D., and Crewther, S. (1990). Neural site of strabismic amblyopia in cats: spatial frequency deficit in primary cortical neurons. *Exp. Brain Res.* *79*, 615–622.
- Crick, F. (1984). Function of the thalamic reticular complex: the searchlight hypothesis. *Proc. Natl. Acad. Sci. USA* *81*, 4586–4590.
- Crick, F., and Koch, C. (1990a). Some reflections on visual awareness. *Cold Spring Harbor Symp. Quant. Biol.* *55*, 953–962.
- Crick, F., and Koch, C. (1990b). Towards a neurobiological theory of consciousness. *Sem. Neurosci.* *2*, 263–275.
- Damasio, A.R. (1985). Disorders of complex visual processing: agnosia, achromatopsia, Balint's syndrome, and related difficulties of orientation and construction. In *Principles of Behavioral Neurology*, M.M. Mesulam, ed. (Philadelphia: Davis).
- Das, A., and Gilbert, C.D. (1995). Receptive field expansion in adult visual cortex is linked to dynamic changes in strength of cortical connections. *J. Neurophysiol.* *74*, 779–792.
- Das, A., and Gilbert, C.D. (1999). Topography of contextual modulations mediated by short-range interactions in primary visual cortex. *Nature* *399*, 655–661.
- Dean, P. (1976). Effects of inferotemporal lesions on the behavior of monkeys. *Psychol. Bull.* *83*, 41–71.
- DeAngelis, G.C., Ghose, G.M., Ohzawa, I., and Freeman, R.D. (1999). Functional micro-organization of primary visual cortex: receptive field analysis of nearby neurons. *J. Neurosci.* *19*, 4046–4064.
- deCharms, R., and Merzenich, M. (1996). Primary cortical representation of sounds by the coordination of action-potential timing. *Nature* *381*, 610–613.
- deCharms, R.C., Blake, D.T., and Merzenich, M.M. (1998). Optimizing sound features for cortical neurons. *Science* *280*, 1439–1443.
- De Oliveira, S.C., Thiele, A., and Hoffmann, K.P. (1997). Synchronization of neuronal activity during stimulus expectation in a direction discrimination task. *J. Neurosci.* *17*, 9248–9260.
- Deppisch, J., Bauer, H.-U., Schillen, T.B., König, P., Pawelzik, K., and Geisel, T. (1993). Alternating oscillatory and stochastic states in a network of spiking neurons. *Network* *4*, 243–257.
- Desimone, R. (1991). Face-selective cells in the temporal cortex of monkeys. *J. Cogn. Neurosci.* *3*, 1–8.
- Desimone, R., and Duncan, J. (1995). Neural mechanisms of selective visual attention. *Annu. Rev. Neurosci.* *18*, 193–222.
- Desimone, R., and Schein, S. (1987). Visual properties of neurons in area V4 of the macaque: sensitivity to stimulus form. *J. Neurophysiol.* *57*, 835–868.
- Desimone, R., and Ungerleider, L. (1986). Multiple visual areas in the caudal superior temporal sulcus of the macaque. *J. Comp. Neurol.* *248*, 164–189.
- Desimone, R., Albright, T.D., Gross, C.G., and Bruce, C. (1984). Stimulus-selective properties of inferior temporal neurons in the macaque. *J. Neurosci.* *4*, 2051–2062.
- Desimone, R., Schein, S.J., Moran, J., and Ungerleider, L.G. (1985). Contour, color and shape analysis beyond the striate cortex. *Vision Res.* *25*, 441–452.
- Dev, P. (1975). Perception of depth surfaces in random-dot stereograms: a neural model. *Int. J. Man-Machine Stud.* *7*, 511–528.
- DeValois, R.L., and DeValois, K.K. (1988). *Spatial Vision* (New York: Oxford University Press).
- DeValois, R.L., Albrecht, D.G., and Thorell, L.G. (1982a). Spatial frequency selectivity of cells in macaque visual cortex. *Vision Res.* *22*, 545–559.
- DeValois, R.L., Yund, E.W., and Hepler, N. (1982b). The orientation and direction selectivity of cells in macaque visual cortex. *Vision Res.* *22*, 531–544.
- DeYoe, E.A., and Van Essen, D.C. (1985). Segregation of efferent connections and receptive field properties in visual area V2 of the macaque. *Nature* *317*, 58–61.
- DeYoe, E.A., and Van Essen, D.C. (1988). Concurrent processing streams in monkey visual cortex. *Trends Neurosci.* *11*, 219–226.
- Diesmann, M., Gewaltig, M.-O., and Aertsen, A. (1997). Cortical synfire activity—a two dimensional state space analysis. In *From Membrane to Mind: Proceedings of the 25th Gottinger Neurobiology Conference*, H. Wässle and N. Elsner, eds. (Stuttgart: Thieme-Verlag).
- Dixon, P., and Shedden, J.M. (1987). Conceptual and physical differences in the category effect. *Percept. Psychophys.* *42*, 457–464.
- Dodwell, P.C., and Humphrey, G.K. (1992). A functional theory of the McCollough effect. *Psych. Rev.* *97*, 78–89.
- Donnelly, N., Humphreys, G.W., and Riddoch, M.J. (1991). Parallel computation of primitive shape descriptions. *J. Exp. Psychol. Hum. Percept. Perform.* *17*, 561–570.
- Donoghue, J.P., Sanes, J.N., Hatsopoulos, N.G., and Gaal, G. (1998). Neural discharge and local field potential oscillations in primate motor cortex during voluntary movement. *J. Neurophysiol.* *79*, 159–173.
- Doupe, A.J. (1997). Song- and order-selective neurons in the songbird anterior forebrain and their emergence during vocal development. *J. Neurosci.* *17*, 1147–1167.
- Dubner, R., and Zeki, S.M. (1971). Response properties and receptive fields of cells in an anatomically defined region of the superior temporal sulcus. *Brain Res.* *35*, 528–532.
- Duncan, J. (1983). Category effects in visual search: a failure to replicate the “oh-zero” phenomenon. *Percept. Psychophys.* *34*, 221–232.
- Duncan, J. (1984). Selective attention and the organization of visual information. *J. Exp. Psychol. Gen.* *113*, 501–517.
- Eckes, C., and Vorbrüggen, C.V. (1996). Combining data-driven and model-based cues for segmentation of video sequences. In *WCNN 1996* (San Diego: Lawrence Erlbaum).
- Eckhorn, R., Bauer, R., Jordan, W., Brosch, M., Kruse, W., Munk, M., and Reitboeck, H.J. (1988). Coherent oscillations: a mechanism for feature linking in the visual cortex? *Biol. Cybern.* *60*, 121–130.

- Eckhorn, R., Frien, A., Bauer, R., Woelbern, T., and Kehr, H. (1993). High frequency 60–90 Hz oscillations in primary visual cortex of awake monkey. *Neuroreport* 4, 243–246.
- Edelman, G.M. (1978). Group selection and phasic reentrant signaling: a theory of higher brain function. In *The Mindful Brain: Cortical Organization and the Group-Selective Theory of Higher Brain Function*. G.M. Edelman and V.B. Mountcastle, eds. (Cambridge, MA: MIT Press).
- Edelman, G.M. (1987). *Neural Darwinism: The Theory of Neuronal Group Selection* (New York: Basic Books).
- Edelman, G.M. (1989). *The Remembered Present: A Biological Theory of Consciousness* (New York: Basic Books).
- Edwards, D.P., Purpura, K.P., and Kaplan, E. (1995). Contrast sensitivity and spatial frequency response of primate cortical neurons in and around the cytochrome oxidase blobs. *Vision Res.* 35, 1501–1523.
- Eggers, H., and Blakemore, C. (1978). Physiological basis of an isometric amblyopia. *Science* 201, 264–267.
- Elder, J., and Zucker, S. (1993). The effect of contour closure on the rapid discrimination of two-dimensional shapes. *Vision Res.* 33, 981–991.
- Engel, A.K., König, P., Gray, C.M., and Singer, W. (1990). Stimulus-dependent neuronal oscillations in cat visual cortex: inter-columnar interaction as determined by cross-correlation analysis. *Eur. J. Neurosci.* 2, 588–606.
- Engel, A.K., König, P., Kreiter, A.K., and Singer, W. (1991a). Inter-hemispheric synchronization of oscillatory neuronal responses in cat visual cortex. *Science* 252, 1177–1179.
- Engel, A.K., Kreiter, A.K., König, P., and Singer, W. (1991b). Synchronization of oscillatory neuronal responses between striate and extrastriate visual cortical areas of the cat. *Proc. Natl. Acad. Sci. USA* 88, 6048–6052.
- Engel, A.K., König, P., and Singer, W. (1991c). Direct physiological evidence for scene segmentation by temporal coding. *Proc. Natl. Acad. Sci. USA* 88, 9136–9140.
- Engel, A.K., König, P., and Singer, W. (1992a). Reply to: The functional nature of neuronal oscillations. *Trends Neurosci.* 15, 387–388.
- Engel, A.K., König, P., Kreiter, A.K., Chillen, T.B., and Singer, W. (1992b). Temporal coding in the visual cortex: new vista on integration in the nervous system. *Trends Neurosci.* 15, 218–225.
- Engel, A.K., Roelfsema, P.R., Fries, P., Brecht, M., and Singer, W. (1997). Role of the temporal domain for response selection and perceptual binding. *Cereb. Cortex* 7, 571–582.
- Eskandar, E.N., and Assad, J.A. (1999). Dissociation of visual motor and predictive signals in parietal cortex during visual guidance. *Nat. Neurosci.* 2, 88–93.
- Fahle, M., and Koch, C. (1995). Spatial displacement, but not temporal asynchrony, destroys figural binding. *Vision Res.* 35, 491–494.
- Fahle, M., and Poggio, T. (1981). Visual hyperacuity: spatio-temporal interpolation in human vision. *Proc. R. Soc. Lond. B Biol. Sci.* 213, 451–477.
- Fang, S.-P., and Wu, P. (1989). Illusory conjunctions in the perception of Chinese characters. *J. Exp. Psychol. Hum. Percept. Perform.* 15, 434–447.
- Felleman, D.J., and Van Essen, D.C. (1987). Receptive field properties of neurons in area V3 of macaque monkey extrastriate cortex. *J. Neurophysiol.* 57, 889–920.
- Felleman, D.J., and van Essen, D.C. (1991). Distributed hierarchical processing in the primate cerebral cortex. *Cereb. Cortex* 1, 1–47.
- Ferrera, V.P., and Lisberger, S.G. (1995). Attention and target selection for smooth pursuit eye movements. *J. Neurosci.* 15, 7472–7484.
- Ferrera, V.P., Rudolph, K.K., and Maunsell, J.H.R. (1994). Responses of neurons in the parietal and temporal visual pathways during a motion task. *J. Neurosci.* 14, 6171–6186.
- Fetz, E., Toyama, K., and Smith, W. (1991). Synaptic interactions between cortical neurons. In *Cerebral Cortex*, A. Peters and E.G. Jones, eds. (New York: Plenum Press).
- Fodor, J.A., and Pylyshyn, Z.W. (1988). Connectionism and cognitive architecture: a critical analysis. *Cognition* 28, 3–71.
- Folk, C.L., and Egeth, H. (1989). Does the identification of simple features require serial processing? *J. Exp. Psychol. Hum. Percept. Perform.* 15, 97–110.
- Foster, K.H., Gaska, J.P., Nagler, M., and Pollen, D.A. (1985). Spatial and temporal frequency selectivity of neurones in visual cortical areas V1 and V2 of the macaque monkey. *J. Physiol. (Lond.)* 365, 331–363.
- Franz, V., Gegenfurtner, K.R., Fahle, M., and Buelthoff, H.H. (1999). Grasping visual illusions: no evidence for a dissociation between perception and action. *Psychol. Sci.*, in press.
- Freeman, W.J. (1975). *Mass Action in the Nervous System* (New York: Academic Press).
- Freeman, W.J., and Skarda, C.A. (1985). Spatial EEG-patterns, nonlinear dynamics and perception: the neo-Sherrington view. *Brain Res. Rev.* 10, 147–175.
- Freiwald, W.A., Kreiter, A.K., and Singer, W. (1995). Stimulus dependent intercolumnar synchronization of single unit responses in cat area 17. *Neuroreport* 6, 2348–2352.
- Friedman-Hill, S.R., Robertson, L.C., and Treisman, A. (1995). Parietal contributions to visual feature binding: evidence from a patient with bilateral lesions. *Science* 269, 853–855.
- Friedman-Hill, S., Maldonado, P.E., and Gray, C.M. (1999). Temporal dynamics of neuronal activity in the striate cortex of alert macaque: I. Incidence and stimulus-dependence of oscillations. *J. Neurosci.*, in press.
- Frien, A., Eckhorn, R., Bauer, R., Woelbern, T., and Kehr, H. (1994). Stimulus-specific fast oscillations at zero phase between visual areas V1 and V2 of awake monkey. *Neuroreport* 5, 2273–2277.
- Fries, P., Roelfsema, P.R., Engel, A.K., König, P., and Singer, W. (1997). Synchronization of oscillatory responses in visual cortex correlates with perception in interocular rivalry. *Proc. Natl. Acad. Sci. USA* 94, 12699–12704.
- Fuji, H., Ito, H., Aihara, K., Ichinose, N., and Tsukada, M. (1996). Dynamical cell assembly hypothesis-theoretical possibility of spatio-temporal coding in the cortex. *Neural Network* 9, 1303–1350.
- Fujita, I., Tanaka, K., Ito, M., and Cheng, K. (1992). Columns for visual features of objects in monkey inferotemporal cortex. *Nature* 360, 343–346.
- Fukushima, K. (1980). Neocognitron: a self-organizing neural network model for a mechanism of pattern recognition unaffected by shift in position. *Biol. Cybern.* 36, 193–202.
- Gallant, J.L., Connor, C.E., Rakshit, S., Lewis, J.W., and Van Essen, D.C. (1996). Neural responses to polar, hyperbolic, and cartesian gratings in area V4 of the macaque monkey. *J. Neurophysiol.* 76, 2718–2739.
- Gattass, R., Sousa, A.P., and Gross, C.G. (1988). Visuotopic organization and extent of V3 and V4 of the macaque. *J. Neurosci.* 8, 1831–1845.
- Gawne, T.J., Kjaer, T.W., and Richmond, B.J. (1996). Latency: another potential code for feature binding in striate cortex. *J. Neurophysiol.* 76, 1356–1360.
- Geesaman, B.J., and Andersen, R.A. (1996). The analysis of complex motion patterns by form/cue invariant MSTd neurons. *J. Neurosci.* 16, 4716–4732.
- Geisler, W.S., and Albrecht, D.G. (1995). Bayesian analysis of identification performance in monkey visual cortex: nonlinear mechanisms and stimulus certainty. *Vision Res.* 35, 2723–2730.
- Georgopoulos, A.P., Ashe, J., Smyrnis, N., and Taira, M. (1992). The motor cortex and the coding of force. *Science* 256, 1692–1695.
- Gerstein, G.L., Bedenbaugh, P., and Aertsen, M.H. (1989). Neuronal assemblies. *IEEE Trans. Biomed. Eng.* 36, 4–14.
- Gerstner, W., and van Hemmen, J.L. (1993). Coherence and incoherence in a globally coupled ensemble of pulse-emitting units. *Phys. Rev. Lett.* 7, 312–315.
- Gerstner, W., Kempter, R., Van Hemmen, J.L., and Wagner, H. (1996). A neuronal learning rule for sub-millisecond temporal coding. *Nature* 383, 76–78.
- Ghose, G.M., and Freeman, R.D. (1992). Oscillatory discharge in the visual system: does it have a functional role? *J. Neurophysiol.* 68, 1558–1574.

- Ghose, G.M., and Freeman, R.D. (1997). Intracortical connections are not required for oscillatory activity in the visual cortex. *Vis. Neurosci.* *14*, 963R-979R.
- Ghose, G.M., and Maunsell, J. (1999). Specialized representations in visual cortex: a role for binding? *Neuron* *24*, this issue, 79-85.
- Ghose, G.M., and Ts'o, D.Y. (1997). Form processing modules in primate area V4. *J. Neurophysiol.* *77*, 2191-2196.
- Gibson, J.R., and Maunsell, J.H.R. (1997). The sensory modality specificity of neural activity related to memory in visual cortex. *J. Neurophysiol.* *78*, 1263-1275.
- Gilbert, C.D., and Wiesel, T.N. (1979). Morphology and intracortical projections of functionally characterized neurones in the cat visual cortex. *Nature* *280*, 120-125.
- Gilbert, C.D., and Wiesel, T.N. (1983). Clustered intrinsic connections in cat visual cortex. *J. Neurosci.* *3*, 1116-1133.
- Gilbert, C.D., and Wiesel, T.N. (1989). Columnar specificity of intrinsic horizontal and cortico-cortical connections in cat visual cortex. *J. Neurosci.* *9*, 2432-2442.
- Givre, S.J., Arezzo, J.C., and Schroeder, C.E. (1995). Effects of wavelength on the timing and laminar distribution of illuminance-evoked activity in macaque V1. *Vis. Neurosci.* *12*, 229-239.
- Gizzi, M.S., Newsome, W.T., and Movshon, J.A. (1983). Directional selectivity of neurons in macaque MT. *Invest. Ophthalm. Vis. Sci.* *24 (suppl.)*, 107.
- Gizzi, M.S., Katz, E., Schumer, R.A., and Movshon, J.A. (1990). Selectivity for orientation and direction of motion of single neurons in cat striate and extrastriate visual cortex. *J. Neurophysiol.* *63*, 1529-1543.
- Goldsmith, M. (1998). What's in a location? Comparing object-based and space-based models of feature integration in visual search. *J. Exp. Psychol.* *127*, 189-219.
- Goldstone, R.L. (1998). Perceptual learning. *Annu. Rev. Psychol.* *49*, 585-612.
- Goodale, M. (1993). Visual pathways supporting perception and action in the primate cerebral cortex. *Curr. Opin. Neurobiol.* *3*, 578-585.
- Goodale, M., and Humphrey, G. (1998). The objects of action and perception. *Cognition* *67*, 181-207.
- Goodale, M.A., and Milner, A.D. (1992). Separate visual pathways for perception and action. *Trends Neurosci.* *15*, 20-25.
- Goodale, M.A., Milner, A.D., Jakobson, L.S., and Carey, D.P. (1991). A neurological dissociation between perceiving objects and grasping them. *Nature* *349*, 154-156.
- Goodale, M.A., Meenan, J.P., Bulthoff, H.H., Nicolle, D.A., Murphy, K. J., and Racicot, C.I. (1994). Separate neural pathways for visual analysis of object shape in perception and prehension. *Curr. Biol.* *4*, 604-610.
- Goolkasian, P. (1988). Illusory conjunctions in the processing of clock times. *J. Gen. Psychol.* *115*, 341-353.
- Gottlieb, J.P., Kusunoki, M., and Goldberg, M.E. (1998). The representation of visual salience in monkey parietal cortex. *Nature* *397*, 481-484.
- Graham, N. (1989). *Visual Pattern Analyzers* (New York: Oxford University Press).
- Gray, C.M. (1994). Synchronous oscillations in neuronal systems: mechanisms and functions. *J. Comput. Neurosci.* *7*, 11-38.
- Gray, C.M. (1999). The temporal correlation hypothesis of visual feature integration: still alive and well. *Neuron* *24*, this issue, 31-47.
- Gray, C.M., and McCormick, D.A. (1996). Chattering cells: superficial pyramidal neurons contributing to the generation of synchronous oscillations in the visual cortex. *Science* *274*, 109-113.
- Gray, C.M., and Singer, W. (1989). Stimulus-specific neuronal oscillations in orientation columns of cat visual cortex. *Proc. Natl. Acad. Sci. USA* *86*, 1698-1702.
- Gray, C.M., and Viana Di Prisco, G. (1997). Stimulus-dependent neuronal oscillations and local synchronization in striate cortex of the alert cat. *J. Neurosci.* *17*, 3239-3253.
- Gray, C.M., Koenig, P., Engel, A.K., and Singer, W. (1989). Oscillatory responses in cat visual cortex exhibit inter-columnar synchronization which reflects global stimulus properties. *Nature* *338*, 334-337.
- Gray, C.M., Engel, A.K., Koenig, P., and Singer, W. (1990). Stimulus-dependent neuronal oscillations in cat visual cortex: receptive field properties and feature dependence. *Eur. J. Neurosci.* *2*, 607-619.
- Gray, C.M., Engel, A.K., Koenig, P., and Singer, W. (1992). Synchronization of oscillatory neuronal responses in cat striate cortex: temporal properties. *Vis. Neurosci.* *8*, 337-347.
- Green, M. (1992). Visual search: detection, identification and localization. *Perception* *21*, 765-777.
- Gregory, R.L. (1970). *The Intelligent Eye* (London: Weidenfield and Nicholson).
- Gross, C.G., Cowey, A., and Manning, F.J. (1971). Further analysis of visual discrimination deficits following foveal prestriate and inferotemporal lesions in rhesus monkeys. *J. Comp. Physiol. Psychol.* *76*, 1-7.
- Gross, C.G., Rocha-Miranda, C.E., and Bender, D.B. (1972). Visual properties of neurons in inferotemporal cortex of the macaque. *J. Neurophysiol.* *35*, 96-111.
- Grossberg, S. (1995). The attentive brain. *Am. Scientist* *83*, 438-449.
- Grossberg, S. (1999a). The link between brain learning, attention, and consciousness. *Conscious. Cogn.*, in press.
- Grossberg, S. (1999b). How does the cerebral cortex work? *Spat. Vis.*, in press.
- Grossberg, S., and Somers, D. (1991). Synchronized oscillations during cooperative feature linking in a cortical model of visual perception. *Neural Networks* *4*, 453-466.
- Haenny, P.D., Maunsell, J.H.R., and Schiller, P.H. (1988). State dependent activity in monkey visual cortex. II. Retinal and extraretinal factors in V4. *Exp. Brain Res.* *69*, 245-259.
- Hata, Y., Tsumoto, T., Sato, H., and Tamura, H. (1991). Horizontal interactions between visual cortical neurones studied by cross-correlation analysis in the cat. *J. Physiol.* *441*, 593-614.
- Hatsopoulos, N.G., Ojakangas, C.L., Paninski, L., and Donoghue, J.P. (1998). Information about movement direction obtained from synchronous activity of motor cortical neurons. *Proc. Natl. Acad. Sci. USA* *95*, 15706-15711.
- Hayek, F.A. (1952). *The Sensory Order* (Chicago: University of Chicago Press).
- Hebb, D.O. (1949). *The Organization of Behavior* (New York: Wiley).
- Heeger, D. (1992). Normalization of cell responses in cat striate cortex. *Vis. Neurosci.* *9*, 181-197.
- Hellwig, B., Schuz, A., and Aertsen, A. (1994). Synapses on axon collaterals of pyramidal cells are spaced at random intervals: a Golgi study in the mouse cerebral cortex. *Biol. Cybern.* *71*, 1-12.
- Herculano-Houzel, S., Munk, M.H., Neuenschwander, S., and Singer, W. (1999). Precisely synchronized oscillatory firing patterns require electroencephalographic activation. *J. Neurosci.* *19*, 3992-4010.
- Hess, R., Campbell, F., and Greenhalgh, T. (1978). On the nature of the neural abnormality in human amblyopia: neural aberrations and neural sensitivity loss. *Pflügers Arch.* *377*, 201-207.
- Hinton, G.E.A. (1981). A parallel computation that assigns canonical object-based frames of reference. In *Proceedings of the Seventh International Joint Conference on Artificial Intelligence, Volume 2* (Vancouver).
- Hoffman, J.E. (1979). A two-stage model of visual search. *Percept. Psychophys.* *25*, 319-327.
- Hoffman, D.A., Magee, J.C., Colbert, C.M., and Johnston, D. (1997). K⁺ channel regulation of signal propagation in dendrites of hippocampal pyramidal neurons. *Nature* *387*, 869-875.
- Hommel, B. (1998). Event files: evidence for automatic integration of stimulus-response episodes. *Vis. Cogn.* *5*, 183-216.
- Hopfield, J.J., and Hertz, A.V.M. (1995). Rapid local synchronization of action potentials: toward computation with coupled integrate-and-fire neurons. *Proc. Natl. Acad. Sci. USA* *92*, 6655-6662.
- Hoppensteadt, F.C., and Izhikevich, E.M. (1998). Thalamo-cortical interactions modeled by weakly connected oscillators: could the brain use FM radio principles? *Biosystems* *48*, 85-94.
- Horwitz, G.D., and Newsome, W.T. (1999). Separate signals for target selection and movement specification in the superior colliculus. *Science* *284*, 1158-1161.

- Houck, M.R., and Hoffman, J.E. (1986). Conjunction of color and form without attention. Evidence from an orientation-contingent color aftereffect. *J. Exp. Psychol. Hum. Percept. Perform.* *12*, 186–199.
- Howard, I.P., and Rogers, B.J. (1995). *Binocular Vision and Stereopsis* (Oxford: Oxford University Press).
- Hubel, D., and Wiesel, T. (1962). Receptive fields, binocular interaction and functional architecture in the cat's visual cortex. *J. Physiol.* *160*, 106–154.
- Hubel, D., and Wiesel, T. (1965). Receptive fields and functional architecture in two nonstriate visual areas (18 and 19) of the cat. *J. Neurophysiol.* *28*, 229–289.
- Hubel, D.H., and Wiesel, T.N. (1968). Receptive fields and functional architecture of monkey striate cortex. *J. Physiol. (Lond.)* *195*, 215–243.
- Hubel, D.H., and Wiesel, T.N. (1974). Sequence regularity and geometry or orientation columns in the monkey striate cortex. *J. Comp. Neurol.* *158*, 267–294.
- Huerta, P.T., and Lisman, J.E. (1996). Low-frequency stimulation at the throughs of Q-oscillation induces long-term depression of previously potentiated CA1 synapses. *J. Neurophysiol.* *75*, 877–884.
- Hummel, J.E., and Biederman, I. (1992). Dynamic binding in a neural network for shape recognition. *Psychol. Rev.* *99*, 480–517.
- Hummel, J.E., and Stankiewicz, B.J. (1996). An architecture for rapid, hierarchical structural description. In *Attention and Performance*, Volume XVI, T. Inui and J. McClelland, eds. (Cambridge, MA: MIT Press).
- Intraub, H. (1981). Identification and naming of briefly glimpsed visual scenes. In *Eye Movement: Cognition and Visual Perception*, D.F. Fisher, R.A. Monty, and J.W. Senders, eds. (Hillsdale, NJ: Lawrence Erlbaum Associates).
- Intraub, H. (1985). Visual dissociation: an illusory conjunction of pictures and forms. *J. Exp. Psychol. Hum. Percept. Perform.* *11*, 431–442.
- Ito, M., and Gilbert, C.D. (1999). Attention modulates contextual influences in the primary visual cortex of alert monkeys. *Neuron* *22*, 593–604.
- Ivry, R.B., and Prinzmetal, W. (1991). Effect of feature similarity on illusory conjunctions. *Percept. Psychophys.* *49*, 105–116.
- Jensen, O., and Lisman, J.E. (1998). An oscillatory short-term memory buffer model can account for data on the Sternberg task. *J. Neurosci.* *18*, 10688–10699.
- Johnston, D., Magee, J.C., Colbert, C.M., and Christie, B.R. (1996). Active properties of neuronal dendrites. *Annu. Rev. Neurosci.* *19*, 165–186.
- Jones, J., and Palmer, L. (1987). An evaluation of the two-dimensional Gabor filter model of simple receptive fields in cat striate cortex. *J. Neurophysiol.* *58*, 1233–1258.
- Jonides, J., and Gleitman, H. (1972). A conceptual category effect in visual search: O as letter or digit. *Percept. Psychophys.* *12*, 457–460.
- Julesz, B. (1975). Experiments in the visual perception of texture. *Sci. Am.* *232*, 34–43.
- Kahneman, D. (1973). *Attention and Effort* (Englewood Cliffs, NJ: Prentice-Hall).
- Kahneman, D., and Henik, A. (1981). Perceptual organization and attention. In *Perceptual Organization*, M. Kubovy and J. Pomerantz, eds. (Hillsdale, NJ: Lawrence Erlbaum Associates).
- Kahneman, D., Treisman, A., and Gibbs, B. (1992). The reviewing of object files: object-specific integration of information. *Cogn. Psychol.* *24*, 175–219.
- Kammen, D.M., Holmes, P.J., and Koch, C. (1989). Origin of oscillations in visual cortex: feedback versus local coupling. In *Models of Brain Functions*, R.M.J. Cotterill, ed. (Cambridge: Cambridge University Press).
- Kanisza, G. (1979). *The Organization of Vision* (New York: Praeger).
- Kapadia, M.K., Ito, M., Gilbert, C.D., and Westheimer, G. (1995). Improvement in visual sensitivity by changes in local context: parallel studies in human observers and in V1 of alert monkeys. *Neuron* *15*, 843–856.
- Kastner, S., De Weerd, P., Desimone, R., and Ungerleider, L.G. (1998). Mechanisms of directed attention in the human extrastriate cortex as revealed by functional MRI. *Science* *282*, 108–111.
- Kastner, S., Pinsk, M.A., De Weerd, P., Desimone, R., and Ungerleider, L.G. (1999). Increased activity in human visual cortex during directed attention in the absence of visual stimulation. *Neuron* *22*, 751–761.
- Kefalea, E. (1998). Object localization and recognition for a grasping robot. In *Proceedings of the 24th Annual Conference of the IEEE Industrial Electronics Society* (Aachen, Germany).
- Keil, K., Müller, M.M., Ray, W.J., Gruber, T., and Elbert, T. (1999). Human gamma band activity and perception of a Gestalt. *J. Neurosci.* *19*, 7152–7161.
- Kersten, D. (1999). High-level vision as statistical inference. In *The Cognitive Neurosciences*, M.S. Gazzaniga, ed. (Cambridge, MA: MIT Press).
- Kilgard, M.P., and Merzenich, M.M. (1998). Plasticity of temporal information processing in the primary auditory cortex. *Nat. Neurosci.* *1*, 727–731.
- Kim, J.-N., and Shadlen, M.N. (1999). Neural correlates of a decision in the dorsolateral prefrontal cortex of the macaque. *Nat. Neurosci.* *2*, 176–185.
- Kiorpes, L., and McKee, S.P. (1999). Amblyopia and its neural basis. *Curr. Opin. Neurobiol.*, in press.
- Kiorpes, L., and Movshon, J.A. (1996). Amblyopia: a developmental disorder of the central visual pathways. *Cold Spring Harbor Symp. Quant. Biol.* *61*, 39–48.
- Kiorpes, L., Kiper, D., O'Keefe, L., Cavanaugh, J., and Movshon, J. (1998). Neuronal correlates of amblyopia in the visual cortex of macaque monkeys with experimental strabismus and anisometropia. *J. Neurosci.* *18*, 6411–6424.
- Kiper, D.C., Gegenfurtner, K.R., and Movshon, J.A. (1996). Cortical oscillatory responses do not affect visual segmentation. *Vision Res.* *36*, 539–544.
- Kisvarday, Z.F., Toth, E., Rausch, M., and Eysel, U.T. (1997). Orientation-specific relationship between populations of excitatory and inhibitory lateral connections in the visual cortex of the cat. *Cereb. Cortex* *7*, 605–618.
- Kobatake, E., and Tanaka, K. (1994). Neuronal selectivities to complex object features in the ventral visual pathway of the macaque cerebral cortex. *J. Neurophys.* *71*, 856–857.
- Kobatake, E., Wang, G., and Tanaka, K. (1998). Effects of shape-discrimination training on the selectivity of inferotemporal cells in adult monkeys. *J. Neurophysiol.* *80*, 324–330.
- Koch, C. (1999). *Biophysics of Computation* (New York: Oxford University Press).
- Koch, C., and Poggio, T. (1999). Predicting the visual world: silence is golden. *Nat. Neurosci.* *2*, 9–10.
- Koch, C., and Ullman, S. (1985). Shifts in selective visual attention: towards the underlying neural circuitry. *Hum. Neurobiol.* *4*, 219–227.
- Koch, C., Rapp, M., and Segev, I. (1996). A brief history of time (constants). *Cereb. Cortex* *6*, 93–101.
- Koffka, K. (1935). *Principles of Gestalt Psychology* (New York: Harcourt, Brace and World).
- Koffka, K. (1969). *The Task of Gestalt Psychology* (Princeton: Princeton University Press).
- Köhler, W. (1930). *Gestalt Psychology* (London: Bell and Sons).
- Köhler, W., and Held, R. (1949). The cortical correlate of pattern vision. *Science* *110*, 414–419.
- Konen, W., and von der Malsburg, C. (1993). Learning to generalize from single examples in the dynamic link architecture. *Neural Comput.* *5*, 719–735.
- Konen, W., Maurer, T., and von der Malsburg, C. (1994). A fast dynamic link matching algorithm for invariant pattern recognition. *Neural Networks* *7*, 1019–1030.
- König, P., and Schillen, T.B. (1991). Stimulus-dependent assembly formation of oscillatory responses: I. Synchronization. *Neural Comput.* *3*, 155–166.
- König, P., Engel, A.K., and Singer, W. (1996). Integrator or coincidence detector? The role of the cortical neuron revisited. *Trends Neurosci.* *19*, 130–137.

- König, P., Engel, A.K., and Singer, W. (1995). Relation between oscillatory activity and long-range synchronization in cat visual cortex. *Proc. Natl. Acad. Sci. USA* *92*, 290–294.
- König, P., Engel, A.K., Löwel, S., and Singer, W. (1993). Squint affects synchronization of oscillatory responses in cat visual cortex. *Eur. J. Neurosci.* *5*, 501–508.
- Kovacs, I., and Julesz, B. (1993). A closed curve is much more than an incomplete one: effect of closure in figure-ground segmentation. *Proc. Natl. Acad. Sci. USA* *90*, 7495–7497.
- Kreiter, A.K., and Singer, W. (1992). Oscillatory neuronal responses in the visual cortex of the awake macaque monkey. *Eur. J. Neurosci.* *4*, 369–375.
- Kreiter, A.K., and Singer, W. (1996). Stimulus-dependent synchronization of neuronal responses in the visual cortex of the awake macaque monkey. *J. Neurosci.* *16*, 2381–2396.
- Krüger, L.E. (1984). The category effect in visual search depends on physical rather than conceptual differences. *Percept. Psychophys.* *35*, 558–564.
- Krüger, J., and Aiple, F. (1988). Multimicroelectrode investigation of monkey striate cortex: spike train correlations in the infragranular layers. *J. Neurophysiol.* *60*, 798–828.
- Kwak, H., Dagenbach, D., and Egeth, H. (1991). Further evidence for a time-independent shift of the focus of attention. *Percept. Psychophys.* *49*, 473–480.
- Lades, M., Vorbrüggen, J.C., Buhmann, J., Lange, J., von der Malsburg, C., Würtz, R., and Konen, W. (1993). Distortion invariant object recognition in the dynamic link architecture. *IEEE Trans. Comput.* *42*, 300–311.
- Lamme, V.A. (1995). The neurophysiology of figure-ground segregation in primary visual cortex. *J. Neurosci.* *15*, 1605–1615.
- Lamme, V.A.F., and Spekreijse, H. (1999). Neuronal synchrony does not represent texture segregation. *Nature* *396*, 362–366.
- Lampl, I., Reichova, I., and Ferster, D. (1999). Synchronous membrane potential fluctuations in neurons of the cat visual cortex. *Neuron* *22*, 361–374.
- Larkum, M.E., Zhu, J.J., and Sakmann, B. (1999). A new cellular mechanism for coupling inputs arriving at different cortical layers. *Nature* *398*, 338–341.
- Lashley, K.S., Chow, K.L., and Semmes, J. (1951). An examination of the electrical field theory of cerebral integration. *Psychol. Rev.* *58*, 128–136.
- Laufer, M., and Verzeano, M. (1967). Periodic activity in the visual system of the cat. *Vision Res.* *7*, 215–229.
- Laurent, G. (1996). Dynamical representation of odors by oscillating and evolving neural assemblies. *Trends Neurosci.* *19*, 489–496.
- Laurent, G., Wehr, M., and Davidowitz, H. (1996). Temporal representations of odors in an olfactory network. *J. Neurosci.* *16*, 3837–3847.
- Lavie, N., and Driver, J. (1996). On the spatial extent of attention in object-based visual selection. *Percept. Psychophys.* *58*, 1238–1251.
- Lee, S.-H., and Blake, R. (1999). Visual form created solely from temporal structure. *Science* *284*, 1165–1168.
- Lee, C., Rohrer, W.H., and Sparks, D.L. (1988). Population coding of saccadic eye movements by neurons in the superior colliculus. *Nature* *332*, 357–360.
- Lee, D., Itti, L., Koch, C., and Braun, J. (1999). Attention activates winner-take-all competition among visual filters. *Nat. Neurosci.* *2*, 375–381.
- Legendy, C. (1970). The brain and its information trapping device. In *Progress in Cybernetics*, Volume 1, J. Rose, ed. (New York: Gordon and Breach).
- Lennie, P. (1981). The physiological basis of variations in visual latency. *Vision Res.* *21*, 815–824.
- Lennie, P., Krauskopf, J., and Sclar, G. (1990). Chromatic mechanisms in striate cortex of macaque. *J. Neurosci.* *10*, 649–669.
- Leon, M.I., and Shadlen, M.N. (1998). Exploring the neurophysiology of decisions. *Neuron* *21*, 669–672.
- Leonards, U., Singer, W., and Fahle, M. (1996). The influence of temporal phase differences on texture segmentation. *Vision Res.* *36*, 2689–2697.
- Leonards, U., and Singer, W. (1998). Two segmentation mechanisms with differential sensitivity for colour and luminance contrast. *Vision Res.* *38*, 101–109.
- Leonards, U., Singer, W., and Fahle, M. (1996). The influence of temporal phase differences on texture segmentation. *Vision Res.* *36*, 2689–2697.
- Leopold, D.A., and Logothetis, N.K. (1996). Activity changes in early visual cortex reflect monkeys' percepts during binocular rivalry. *Nature* *379*, 549–553.
- Leventhal, A.G., Thompson, K.G., Liu, D., Zhou, Y., and Ault, S.J. (1995). Concomitant sensitivity to orientation, direction, and color of cells in Layers 2, 3, and 4 of monkey striate cortex. *J. Neurosci.* *15*, 1808–1818.
- Levi, D., and Sharma, V. (1998). Integration of local orientation in strabismic amblyopia. *Vision Res.* *38*, 775–781.
- Levick, W.R., and Zacks, J.L. (1970). Responses of cat retinal ganglion cells to brief flashes of light. *J. Physiol. (Lond.)* *206*, 677–700.
- Levitt, J.B., and Lund, J.S. (1997). Contrast dependence of contextual effects in primate visual cortex. *Nature* *387*, 73–76.
- Levitt, J.B., Kiper, D.C., and Movshon, J.A. (1994). Receptive field and functional architecture of macaque V2. *J. Neurophysiol.* *71*, 2517–2542.
- Levitt, J.B., Lund, J.S., and Yoshioka, T. (1996). Anatomical substrates for early stages in cortical processing of visual information in the macaque monkey. *Behav. Brain Res.* *76*, 5–19.
- Li, C.-Y., and Li, W. (1994). Extensive integration field beyond the classical receptive field of cat striate cortical neurons-classification and tuning properties. *Vision Res.* *34*, 2337–2355.
- Li, Z. (1999a). Visual segmentation by contextual influences via intracortical interactions in the primary visual cortex. *Network Comput. Neural Syst.* *10*, 187–212.
- Li, Z. (1999b). A neural model of contour integration in the primary visual cortex. *Neural Comput.*, in press.
- Lisberger, S.G., and Movshon, J.A. (1999). Visual motion analysis for pursuit eye movements in area MT of macaque monkeys. *J. Neurosci.* *19*, 2224–2246.
- Lisman, J.E. (1997). Bursts as a unit of neural information: making unreliable synapses reliable. *Trends Neurosci.* *20*, 38–43.
- Lisman, J.E., and Idiart, M.A. (1995). Storage of 7 ± 2 short-term memories in oscillatory subcycles. *Science* *267*, 1512–1515.
- Livingstone, M.S. (1996). Oscillatory firing and interneuronal correlations in squirrel monkey striate cortex. *J. Neurophysiol.* *75*, 2467–2485.
- Livingstone, M.S., and Hubel, D.H. (1983). Specificity of cortico-cortical connections in monkey visual system. *Nature* *304*, 531–534.
- Livingstone, M.S., and Hubel, D.H. (1984). Anatomy and physiology of a color system in the primate visual cortex. *J. Neurosci.* *4*, 309–356.
- Livingstone, M.S., and Hubel, D.H. (1988). Segregation of form, color, movement, and depth: anatomy, physiology, and perception. *Science* *240*, 740–749.
- Llinas, R.R. (1988). The intrinsic electrophysiological properties of mammalian neurons: insights into central nervous system function. *Science* *242*, 1654–1664.
- Llinas, R., and Ribary, U. (1993). Coherent 40 Hz oscillation characterizes dream state in humans. *Proc. Natl. Acad. Sci. USA* *90*, 2078–2081.
- Llinas, R.R., Grace, A.A., and Yarom, Y. (1991). In vitro neurons in mammalian cortical layer 4 exhibit intrinsic oscillatory activity in the 10- to 50-Hz frequency range. *Proc. Natl. Acad. Sci. USA* *88*, 897–901.
- Löwel, S., and Singer, W. (1992). Selection of intrinsic horizontal connections in the visual cortex by correlated neuronal activity. *Science* *255*, 209–212.
- Logothetis, N.K. (1998). Single units and conscious vision. *Philos. Trans. R. Soc. Lond. B Biol. Sci.* *353*, 1801–1818.
- Logothetis, N.K., and Pauls, J. (1995). Psychophysical and physiological evidence for viewer-centered object representations in the primate. *Cereb. Cortex* *5*, 270–288.

- Logothetis, N.K., and Schall, J.D. (1989a). Neuronal activity related to motion perception in the middle temporal (MT) visual area of the macaque. In *Neural Mechanisms of Visual Perception: Proceedings of the Retina Research Foundation*, D.M.-K. Lam and C.D. Gilbert, eds. (The Woodlands, TX: Portfolio Publishing Company).
- Logothetis, N.K., and Schall, J.D. (1989b). Neuronal correlates of subjective visual perception. *Science* **245**, 761–763.
- Logothetis, N.K., Pauls, J., and Poggio, T. (1995). Shape representation in the inferior temporal cortex of monkeys. *Curr. Biol.* **5**, 552–563.
- Luck, S.J., and Vogel, E.K. (1997). The capacity of visual working memory for features and conjunctions. *Nature* **390**, 279–281.
- Luck, S.J., Chelazzi, L., Hillyard, S.A., and Desimone, R. (1997a). Neural mechanisms of spatial selective attention in areas V1, V2, and V4 of macaque visual cortex. *J. Neurophysiol.* **77**, 24–42.
- Luck, S.J., Girelli, M., McDermott, M.T., and Ford, M.A. (1997b). Bridging the gap between monkey neurophysiology and human perception: an ambiguity resolution theory of visual selective attention. *Cogn. Psychol.* **33**, 64–87.
- Lumer, E.D., Edelman, G.M., and Tononi, G. (1997a). Neural dynamic in a model of the thalamocortical system. I. Layers, loops and the emergence of fast synchronous rhythms. *Cereb. Cortex* **7**, 207–227.
- Lumer, E.D., Edelman, G.M., and Tononi, G. (1997b). Neural dynamics in a model of the thalamocortical system. II. The role of neural synchrony tested through perturbations of spike timing. *Cereb. Cortex* **7**, 228–236.
- Luthi, A., and McCormick, D.A. (1998). H-current: properties of a neuronal and network pacemaker. *Neuron* **21**, 9–12.
- Lytton, W.W., and Sejnowski, T.J. (1991). Simulations of cortical pyramidal neurons synchronized by inhibitory interneurons. *J. Neurophysiol.* **66**, 1059–1079.
- MacLeod, K., and Laurent, G. (1996). Distinct mechanisms for synchronization and temporal patterning of odor-encoding neural assemblies. *Science* **274**, 976–979.
- MacLeod, K., Backer, A., and Laurent, G. (1998). Who reads temporal information contained across synchronized and oscillatory spike trains? *Nature* **395**, 693–698.
- Madler, C., and Poppel, E. (1987). Auditory evoked potentials indicate the loss of neuronal oscillations during general anesthesia. *Naturwissenschaften* **74**, 42–43.
- Magee, J.C., and Johnston, D.A. (1997). A synaptically controlled, associative signal for Hebbian plasticity in hippocampal neurons. *Science* **275**, 209–213.
- Mainen, Z.F., and Sejnowski, T.J. (1995). Reliability of spike timing in neocortical neurons. *Science* **268**, 1503–1506.
- Malach, R., Amir, Y., Harel, M., and Grinvald, A. (1993). Relationship between intrinsic connections and functional architecture revealed by optical imaging and in vivo targeted biocytin injections in primate striate cortex. *Proc. Natl. Acad. Sci. USA* **90**, 10469–10473.
- Maldonado, P.E., Friedman-Hill, S.R., and Gray, C.M. (1999). Temporal dynamics of neuronal activity in the striate cortex of alert macaque: II. Short and long-range temporally-correlated activity. *J. Neurosci.*, in press.
- Marcelja, S. (1980). Mathematical description of the responses of simple cortical cells. *J. Optic. Soc. Am.* **70**, 1297–1300.
- Margulis, M., and Tang, C.-M. (1998). Temporal integration can readily switch between sublinear and supralinear summation. *J. Neurophysiol.* **79**, 2809–2813.
- Markram, H., Lübke, J., Frotscher, M., and Sakmann, B. (1997). Regulation of synaptic efficacy by coincidence of postsynaptic APs and EPSPs. *Science* **275**, 213–215.
- Marr, D. (1982). *Vision* (San Francisco: Freeman).
- Marsalek, P., Koch, C., and Maunsell, J.H.R. (1997). On the relationship between synaptic input and spike output jitter in individual neurons. *Proc. Natl. Acad. Sci. USA* **94**, 735–740.
- Mason, A., Nicoll, A., and Stratford, K. (1991). Synaptic transmission between individual pyramidal neurons of the rat visual cortex in vitro. *J. Neurosci.* **11**, 72–84.
- Massad, A., Mertsching, B., and Schmalz, S. (1998). Combining multiple views and temporal associations for 3-D object recognition. In *Proceedings of the ECCV 1998, Volume 2 Stockholm*.
- Matsumura, M., Chen, D.-F., Sawaguchi, T., Kubota, K., and Fetz, E.E. (1996). Synaptic interactions between primate precentral cortex neurons revealed by spike-triggered averaging of intracellular membrane potentials in vivo. *J. Neurosci.* **16**, 7757–7767.
- Maunsell, J.H.R., and Gibson, J.R. (1992). Visual response latencies in striate cortex of the macaque monkey. *J. Neurophysiol.* **68**, 1332–1344.
- Maunsell, J.H.R., and Newsome, W.T. (1987). Visual processing in monkey extrastriate cortex. *Annu. Rev. Neurosci.* **10**, 363–401.
- Maunsell, J.H., Sclar, G., Nealey, T.A., and DePriest, D.D. (1991). Extraretinal representations in area V4 in the macaque monkey. *Vis. Neurosci.* **7**, 561–573.
- Maunsell, J.H.R., Ghose, G.M., Assad, J.A., McAdams, C.J., Boudreau, C.E., and Noerager, B.D. (1999). Visual response latencies of magnocellular and parvocellular LGN neurons in macaque monkeys. *Vis. Neurosci.* **16**, 1–14.
- McAdams, C.J., and Maunsell, J.H.R. (1999). Effects of attention on orientation-tuning functions of single neurons in macaque cortical area V4. *J. Neurosci.* **19**, 431–441.
- McClelland, J.L., and Mozer, M.C. (1986). Perceptual interactions in two-word displays: familiarity and similarity effects. *J. Exp. Psychol. Hum. Percept. Perform.* **12**, 18–35.
- McCullough, C. (1965). Color adaptation of edge-detectors in the human visual system. *Science* **149**, 1115–1116.
- McCulloch, W., and Pitts, W. (1943). A logical calculus of the ideas immanent in nervous activity. *Bull. Math. Biophys.* **5**, 115–133.
- McCormick, D.A., Connors, B.W., Lighthall, J.W., and Prince, D.A. (1985). Comparative electrophysiology of pyramidal and sparsely spiny stellate neurons of the neocortex. *J. Neurophysiol.* **54**, 782–806.
- McLeod, P., Driver, J., and Crisp, J. (1988). Visual search for conjunctions of movement and form is parallel. *Nature* **332**, 154–155.
- McLeod, P., Driver, J., Dienes, Z., and Crisp, J. (1991). Filtering by movement in visual search. *J. Exp. Psychol. Hum. Percept. Perform.* **17**, 55–64.
- Mel, B., and Fiser, J. (1999). Minimizing binding errors using learned conjunctive features. *Neural Comput.*, in press.
- Melssen, W.J., and Epping, W.J.M. (1987). Detection and estimation of neural connectivity based on cross correlation analysis. *Biol. Cybern.* **57**, 403–414.
- Merigan, W.H., and Maunsell, J.H. (1993). How parallel are the primate visual pathways? *Annu. Rev. Neurosci.* **16**, 369–402.
- Michalski, A., Gerstein, G.L., Czarkowska, J., and Tarnecki, R. (1983). Interactions between cat striate cortex neurons. *Exp. Brain Res.* **51**, 97–107.
- Mikami, A., Newsome, W.T., and Wurtz, R.H. (1986). Motion selectivity in macaque visual cortex. I. Mechanisms of direction and speed selectivity in extrastriate area MT. *J. Neurophysiol.* **55**, 1308–1327.
- Miles, R., and Wong, R.K.S. (1986). *J. Physiol.* **380**, 373–397.
- Miller, E.C., Gochin, P.M., and Gross, C.G. (1993). Suppression of visual responses of neurons in inferior temporal cortex of the awake macaque monkey by addition of a second stimulus. *Brain Res.* **616**, 25–29.
- Milner, P. (1974). A model for visual shape recognition. *Psychol. Rev.* **81**, 521–535.
- Milner, A.D., and Goodale, M.A. (1993). Visual pathways to perception and action. *Prog. Brain Res.* **95**, 317–337.
- Miltner, W.H.R., Braun, C., Arnold, M., Witte, H., and Taub, E. (1999). Coherence of gamma-band EEG activity as a basis for associative learning. *Nature* **397**, 434–436.
- Minsky, M. (1961). Steps toward artificial intelligence. *Proc. Inst. Radio Engr.* **49**, 8–30.
- Missal, M., Vogels, R., and Orban, G. (1997). Responses of macaque inferior temporal neurons to overlapping shapes. *Cereb. Cortex* **7**, 758–767.
- Moore, G.P., Segundo, J.P., Perkel, D.H., and Levitan, H. (1970). Statistical signs of synaptic interactions in neurones. *Biophys. J.* **10**, 876–900.
- Moran, J., and Desimone, R. (1985). Selective attention gates visual processing in the extrastriate cortex. *Science* **229**, 782–784.

- Motter, B.C. (1993). Focal attention produces spatially selective processing in visual cortical areas V1, V2, and V4 in the presence of competing stimuli. *J. Neurophysiol.* *70*, 909–919.
- Motter, B.C., and Mountcastle, V.B. (1981). The functional properties of the light-sensitive neurons of the posterior parietal cortex studied in waking monkeys: foveal sparing and opponent vector organization. *J. Neurosci.* *1*, 3–26.
- Mountcastle, V.B. (1978). An organizing principle for cerebral function: the unit module and the distributed system. In *The Mindful Brain*, G.M. Edelman and V.B. Mountcastle, eds. (Cambridge, MA: MIT Press).
- Movshon, J.A., Adelson, E.H., Gizzi, M.S., and Newsome, W.T. (1985). The analysis of moving visual patterns. *Exp. Brain Res.* *71*, 117–151.
- Movshon, J., Eggers, H., Gizzi, M., Hendrickson, A., Kiorpes, L., and Boothe, R. (1987). Effects of early unilateral blur on the macaque's visual system. III. Physiological observations. *J. Neurosci.* *7*, 1340–1351.
- Mozer, M.C. (1983). Letter migration in word perception. *J. Exp. Psychol. Hum. Percept. Perform.* *9*, 531–546.
- Mozer, M. (1991). *The Perception of Multiple Objects: A Connectionist Approach* (Cambridge, MA: MIT Press).
- Munk, M.H.J., Roelfsema, P.R., König, P., Engel, A.K., and Singer, W. (1996). Role of reticular activation in the modulation of intracortical synchronization. *Science* *272*, 271–274.
- Murata, A., Gallese, V., Kaseda, M., and Sakata, H. (1996). Parietal neurons related to memory-guided hand manipulation. *J. Neurophysiol.* *75*, 2180–2186.
- Murthy, V.N., and Fetz, E.E. (1996a). Oscillatory activity in sensorimotor cortex of awake monkeys: synchronization of local field potentials and relation to behavior. *J. Neurophysiol.* *76*, 3949–3967.
- Murthy, V.N., and Fetz, E.E. (1996b). Synchronization of neurons during local field potential oscillations in sensorimotor cortex of awake monkeys. *J. Neurophysiol.* *76*, 3968–3982.
- Nakayama, K., and Silverman, G.H. (1986a). Serial and parallel processing of visual feature conjunctions. *Nature* *320*, 264–265.
- Navon, D. (1975). Forest before trees: the precedence of global features in visual perception. *Cogn. Psychol.* *9*, 353–383.
- Neisser, U. (1963). Decision-time without reaction-time: experiments in visual scanning. *Am. J. Psychol.* *76*, 376–385.
- Neisser, U. (1967). *Cognitive Psychology* (New York: Appleton-Century-Crofts).
- Neisser, U., and Becklen, R. (1975). Selective looking: attending to visually specified events. *Cogn. Psychol.* *7*, 480–494.
- Nelson, J.I., Salin, P.A., Munk, M.H.J., Arzi, M., and Bullier, J. (1992). Spatial and temporal coherence in cortico-cortical connections: a cross-correlation study in areas 17 and 18 in the cat. *Vis. Neurosci.* *9*, 21–38.
- Neuenschwander, S., and Singer, W. (1996). Long-range synchronization of oscillatory light responses in the cat retina and lateral geniculate nucleus. *Nature* *379*, 728–733.
- Neuenschwander, S., Castelo-Branco, M., and Singer, W. (1999). Synchronous oscillations in the cat retina. *Vision Res.* *39*, 2485–2497.
- Neven, H., and Aertsen, A. (1992). Rate coherence and event coherence in the visual cortex: a neuronal model of object recognition. *Biol. Cybern.* *67*, 309–322.
- Newsome, W.T., Britten, K.H., and Movshon, J.A. (1989). Neuronal correlates of a perceptual decision. *Nature* *341*, 52–54.
- Nicolelis, M.A.L., and Chapin, J.K. (1994). Spatiotemporal structure of somatosensory responses of many-neuron ensembles in the rat ventral posterior medial nucleus of the thalamus. *J. Neurosci.* *14*, 3511–3532.
- Nicolelis, M.A., Ghazanfar, A.A., Stambaugh, C.R., Oliveira, L.M., Laubach, M., Chapin, J.K., Nelson, R.J., and Kaas, J.H. (1998). Simultaneous encoding of tactile information by three primate cortical areas. *Nat. Neurosci.* *1*, 621–630.
- Nicoll, A., and Blakemore, C. (1993). Single-fiber EPSPs in layer 5 of rat visual cortex in-vitro. *Neuroreport* *4*, 167–170.
- Niebur, E., Kammen, D.M., and Koch, C. (1990). Phase-locking in 1-D and 2-D networks of oscillating neurons. In *Nonlinear Dynamics and Neuronal Networks*, H.G. Schuster, ed. (Weinheim: VCH Publishers).
- Niebur, E., Koch, C., and Rosin, C. (1993). An oscillation-based model for the neuronal basis of attention. *Vision Res.* *33*, 2789–2802.
- Nobre, A.C., Sebestyen, G.N., Gitelman, D.R., Mesulam, M.M., Frackowiak, R.S., and Frith, C.D. (1997). Functional localization of the system for visuospatial attention using positron emission tomography. *Brain* *120*, 515–533.
- Nothdurft, H.C. (1992). Feature analysis and the role of similarity in pre-attentive vision. *Percept. Psychophys.* *52*, 355–375.
- Nothdurft, H.C. (1993). Faces and facial expression do not pop-out. *Perception* *22*, 1287–1298.
- Nowak, L.G., Munk, M.H., Girard, P., and Bullier, J. (1995a). Visual latencies in areas V1 and V2 of the macaque monkey. *Vis. Neurosci.* *12*, 371–384.
- Nowak, L.G., Munk, M.H., Nelson, J.I., James, A.C., and Bullier, J. (1995b). Structural basis of cortical synchronization. I. Three types of interhemispheric coupling. *J. Neurophysiol.* *74*, 2379–2400.
- Nowak, L.G., Munk, M.H., James, A.C., Girard, P., and Bullier, J. (1999). Cross-correlation study of the temporal interactions between areas V1 and V2 of the macaque monkey. *J. Neurophysiol.* *81*, 1057–1074.
- Nowlan, S., and Sejnowski, T. (1995). A selection model for motion processing in area MT of primates. *J. Neurosci.* *15*, 1195–1214.
- Okada, K., Steffens J., Maurer, T., Hong, H., Elagin, E., Neven, H., and von der Malsburg, C. (1998). The Bochum/USC face recognition system and how it fared in the FERET phase III test. In *Face Recognition: From Theory to Applications*, H. Wechsler, P.J. Phillips, V. Bruce, F. Fogelman-Souli, and T.S. Huang, eds. (New York: Springer-Verlag).
- O'Keefe, L.P., and Movshon, J.A. (1998). Processing of first- and second-order motion signals by neurons in area MT of the macaque monkey. *Vis. Neurosci.* *15*, 305–317.
- Oliva, A., and Schyns, P.G. (1997). Coarse blobs or fine edges? Evidence that information diagnosticity changes the perception of complex visual stimuli. *Cogn. Psychol.* *34*, 72–107.
- Olshausen, B.A., Anderson, C.H., and Van Essen, D.C. (1993). A neurobiological model of visual attention and invariant pattern recognition based on dynamic routing of information. *J. Neurosci.* *13*, 4700–4719.
- Olshausen, B., Anderson, C., and Van Essen, D. (1995). A multiscale dynamic routing circuit for forming size- and position-invariant object representations. *J. Comput. Neurosci.* *2*, 45–62.
- Orban, G.A., Kennedy, H., and Bullier, J. (1986). Velocity sensitivity and direction selectivity of neurons in areas V1 and V2 of the monkey: influence of eccentricity. *J. Neurophysiol.* *56*, 462–480.
- Pal, N.R., and Pal, S.K. (1993). A review of image segmentation techniques. *Pattern Recog. Lett.* *26*, 1277–1294.
- Palm, G. (1981). Towards a theory of cell assemblies. *Biol. Cybern.* *39*, 181–194.
- Palm, G. (1990). Cell assemblies as a guideline for brain research. *Concepts Neurosci.* *1*, 133–137.
- Palm, G., Aertsen, A., and Gerstein, G.L. (1988). On the significance of correlations among neuronal spike trains. *Biol. Cybern.* *59*, 1–11.
- Parker, A.J., and Newsome, W.T. (1998). Sense and the single neuron: probing the physiology of perception. *Annu. Rev. Neurosci.* *21*, 227–277.
- Perkel, D.H., Gerstein, G.L., and Moore, G.P. (1967). Neuronal spike trains and stochastic point processes. I. The single spike train. *Biophys. J.* *7*, 391–418.
- Perrett, D., and Oram, M. (1993). Neurophysiology of shape processing. *Imag. Vis. Comput.* *11*, 317–333.
- Perrett, D., and Oram, M. (1998). Visual recognition based on temporal cortex cells: viewer-centred processing of pattern configuration. *Z. Naturforsch.* *53c*, 518–541.
- Perrett, D.I., Smith, P.A.J., Potter, D.D., Mistlin, A.J., Head, A.S., Milner, A.D., and Jeeves, M.A. (1984). Neurones responsive to faces

- in the temporal cortex: studies of functional organization, sensitivity to identity and relation to perception. *Hum. Neurobiol.* 3, 197–208.
- Perrett, D.I., Smith, P.A.J., Potter, D.D., Mistlin, A.J., Head, A.S., Milner, A.D., and Jeeves, M.A. (1985). Visual cells in the temporal cortex sensitive to face view and gaze direction. *Proc. R. Soc. Lond. B Biol. Sci.* 223, 293–317.
- Perrett, D.I., Mistlin, A.J., and Chitty, A.J. (1987). Visual neurones responsive to faces. *Trends Neurosci.* 10, 358–364.
- Perrett, D., Oram, M., Harries, M., Bevan, R., Hietanen, J., Benson, P., and Thomas, S. (1991). Viewer-centred and object-centred coding of heads in the macaque temporal cortex. *Exp. Brain Res.* 86, 159–173.
- Peterhans, E., and von der Heydt, R. (1993). Functional organization of area V2 in the alert macaque. *J. Neurosci.* 5, 509–524.
- Peters, A., and Sethares, C. (1991). Organization of pyramidal neurons in area 17 of monkey visual cortex. *J. Comp. Neurol.* 306, 1–23.
- Peters, A., and Yilmaz, E. (1993). Neuronal organization in area 17 of cat visual cortex. *Cereb. Cortex* 3, 49–68.
- Phillips, W.A., and Singer, W. (1997). In search of common foundations for cortical computation. *Behav. Brain Sci.* 20, 657–722.
- Phillips, W.A., Hancock, P.J.B., Willson, N.J., and Smith, L.S. (1988). On the acquisition of object concepts from sensory data. In *Neural Computers*. R. Eckmiller and C. von der Malsburg, eds. (Heidelberg: Springer).
- Phillips, P.J., Moon, H., Rizvi, S., and Rauss, P. (1998). The FERET valuation. In *Face Recognition: From Theory to Applications*. H. Wechsler, P.J. Phillips, V. Bruce, F. Fogelman-Souli, and T.S. Huang, eds. (New York: Springer-Verlag).
- Platt, M.L., and Glimcher, P.W. (1997). Responses of intraparietal neurons to saccadic targets and visual distractors. *J. Neurophysiol.* 78, 1574–1589.
- Plenz, D., and Kitai, S.T. (1996). Generation of high-frequency oscillations in local circuits of rat somatosensory cortex cultures. *J. Neurophysiol.* 76, 4180–4184.
- Poggio, T., and Edelman, S. (1990). A network that learns to recognize 3D objects. *Nature* 343, 263–266.
- Poggio, G.F., and Fischer, B. (1977). Binocular interaction and depth sensitivity in striate and prestriate cortex of behaving rhesus monkey. *J. Neurophysiol.* 40, 1392–1405.
- Poggio, T., Reichardt, W., and Hausen, W. (1981). A neuronal circuitry for relative movement discrimination by the visual system of the fly. *Naturwissenschaften* 68, 443–466.
- Polat, U., Sagi, D., and Norcia, A. (1997). Abnormal long-range spatial interactions in amblyopia. *Vision Res.* 37, 737–744.
- Polat, U., Mizobe, K., Pettet, M.W., Kasamatsu, T., and Norcia, A.M. (1998). Collinear stimuli regulate visual responses depending on a cell's contrast threshold. *Nature* 391, 580–584.
- Pomerantz, J. (1981). Perceptual organization in information processing. In *Perceptual Organization*, M. Kubovy and J. Pomerantz, eds. (Hillsdale, NJ: Lawrence Erlbaum Associates).
- Potter, M. (1975). Meaning in visual search. *Science* 187, 565–566.
- Potter, M.C., and Levy, E.I. (1969). Recognition memory for a rapid sequence of pictures. *J. Exp. Psychol.* 81, 10–15.
- Pouget, A., and Sejnowski, T.J. (1997). A new view of hemineglect based on the response properties of parietal neurones. *Philos. Trans. R. Soc. Lond. B Biol. Sci.* 352, 1449–1459.
- Prinzmetal, W. (1981). Principles of feature integration in visual perception. *Percept. Psychophys.* 30, 330–340.
- Prinzmetal, W., and Keysar, B. (1989). Functional theory of illusory conjunctions and neon colors. *J. Exp. Psychol. Gen.* 118, 165–190.
- Prinzmetal, W., Presti, D.E., and Posner, M.I. (1986). Does attention affect visual feature integration? *J. Exp. Psychol. Hum. Percept. Perform.* 12, 361–369.
- Prinzmetal, W., Henderson, D., and Ivry, R. (1995). Loosening the constraints on illusory conjunctions: assessing the roles of exposure duration and attention. *J. Exp. Psychol. Hum. Percept. Perform.* 21, 1362–1375.
- Prut, Y., Vaadia, E., Bergman, H., Haalman, I., Slovlin, H., and Abeles, M. (1998). Spatiotemporal structure of cortical activity: properties and behavioral relevance. *J. Neurophysiol.* 7, 2857–2874.
- Pulvermüller, F., Birbaumer, N., Lutzenberger, W., and Mohr, B. (1997). High frequency brain activity: its possible role in attention, perception and language processing. *Prog. Neurobiol.* 52, 427–445.
- Purves, D., and LaMantia, A.-S. (1990). Number of 'blobs' in the primary visual cortex of neonatal and adult monkeys. *Proc. Natl. Acad. Sci. USA* 87, 5764–5767.
- Qian, N., and Andersen, R.A. (1994). Transparent motion perception as detection of unbalanced motion signals. II. Physiology. *J. Neurosci.* 14, 7367–7380.
- Quinlan, P.T., and Humphreys, G.W. (1987). Visual search for targets defined by combinations of color, shape, and size: an examination of the task constraints on feature and conjunction searches. *Percept. Psychophys.* 41, 455–472.
- Rafal, R.D. (1997). Balint syndrome. In *Behavioral neurology and Neuropsychology*, T.E. Feinberg and M.J. Farah, eds. (New York: McGraw-Hill).
- Rager, G., and Singer, W. (1998). The response of cat visual cortex to flicker stimuli of variable frequency. *Eur. J. Neurosci.* 10, 1856–1877.
- Raiguel, S.E., Lagae, L., Gulyas, B., and Orban, G.A. (1989). Response latencies of visual cells in macaque areas V1, V2 and V5. *Brain Res.* 493, 155–159.
- Rainer, G., Asaad, W.F., and Miller, E.K. (1998). Memory fields of neurons in the primate prefrontal cortex. *Proc. Natl. Acad. Sci. USA* 95, 15008–15013.
- Recanzone, G.H., Wurtz, R.H., and Schwarz, U. (1997). Responses of MT and MST neurons to one and two moving objects in the receptive field. *J. Neurophysiol.* 78, 2904–2915.
- Reitboeck, H.J., Eckhorn, R., and Pabst, M. (1987). A model of figure/ground separation based on correlated neural activity in the visual system. In *Synergetics of the Brain*, H. Haken, ed. (New York: Springer).
- Rensink, R.A., and Enns, J.T. (1995). Preemption effects in visual search: evidence for low-level grouping. *Psychol. Rev.* 102, 101–130.
- Reyes, A.D., and Fetz, E.E. (1993). Two modes of interspike interval shortening by brief transient depolarizations in cat neocortical neurons. *J. Neurophysiol.* 69, 1661–1672.
- Reyes, A., Rubel, E., and Spain, W. (1994). Membrane properties underlying the firing of neurons in the avian cochlear nucleus. *J. Neurosci.* 14, 5352–5364.
- Reyes, A., Rubel, E., and Spain, W. (1996). In vitro analysis of optimal stimuli for phase-locking and time-delayed modulation of firing in avian nucleus laminaris neurons. *J. Neurosci.* 16, 993–1007.
- Reynolds, J.H., and Desimone, R. (1999). The role of neural mechanisms of attention in solving the binding problem. *Neuron* 24, this issue, 19–29.
- Reynolds, J., Chelazzi, L., and Desimone, R. (1999). Competitive mechanisms subserve attention in macaque areas V2 and V4. *J. Neurosci.* 19, 1736–1753.
- Rhodes, P., and Gray, C.M. (1994). Simulations of intrinsically bursting neocortical pyramidal neurons. *Neural Comput.* 6, 1086–1110.
- Ribary, U., Joannides, A.A., Singh, K.D., Hasson, R., Bolton, J.P.R., Lado, F., Mogilner, A., and Llinas, R. (1991). Magnetic field tomography of coherent thalamocortical 40 Hz oscillations in humans. *Proc. Natl. Acad. Sci. USA* 88, 11037–11041.
- Riehle, A., Grun, S., Diesmann, M., and Aertsen, A. (1997). Spike synchronization and rate modulation differentially involved in motor cortical function. *Science* 278, 1950–1953.
- Riesenhuber, M., and Poggio, T. (1998a). Just one view: invariances in inferotemporal cell tuning. In *Advances in Neural Information Processing Systems*, Volume 10, M. Jordan, M. Kearns, and S. Solla, eds. (Cambridge, MA: MIT Press).
- Riesenhuber, M., and Poggio, T. (1998b). Modeling Invariances in Inferotemporal Cell Tuning, Technical Report 1629 (Cambridge, MA: MIT Artificial Intelligence Laboratory).
- Riesenhuber, M., and Poggio, T. (1999a). Are cortical models really bound by the "binding problem"? *Neuron* 24, this issue, 87–93.
- Riesenhuber, M., and Poggio, T. (1999b). Hierarchical models of object recognition in cortex. *Nat. Neurosci.*, in press.
- Rizzolatti, G., Fogassi, L., and Gallese, V. (1997). Parietal cortex: from sight to action. *Curr. Opin. Neurobiol.* 7, 562–567.

- Robertson, L., Treisman, A., Freidman-Hill, S., and Grabowecky, M. (1997). The interaction of spatial and object pathways: evidence from Balint's syndrome. *J. Cogn. Neurosci.* 9, 254–276.
- Rock, I., and Brosgole, L. (1964). Grouping based on phenomenal proximity. *J. Exp. Psychol.* 67, 531–538.
- Rockel, A.J., Hiorns, R.W., and Powell, T.P.S. (1980). The basic uniformity in structure of the neocortex. *Brain* 103, 221–244.
- Rockland, K.S. (1997). Elements of cortical architecture: hierarchy revisited. In *Cerebral Cortex: Extrastriate Cortex in Primate*, K. Rockland, J. Kaas, and A. Peters, eds. (New York: Plenum Publishing Corporation).
- Rockland, K.S., and Lund, J.S. (1982). Widespread periodic intrinsic connections in the tree shrew visual cortex. *Science* 215, 1532–1534.
- Rockland, K.S., and Van Hoesen, G.W. (1994). Direct temporal-occipital feedback connections to striate cortex (V1) in the macaque monkey. *Cereb. Cortex* 4, 300–313.
- Rodman, H.R., and Albright, T.D. (1989). Single-unit analysis of pattern-motion selective properties in the middle temporal visual area (MT). *Exp. Brain Res.* 75, 53–64.
- Rodriguez, E., George, N., Lachaux, J.-P., Martinerie, J., Renault, B., and Varela, F.J. (1999). Perception's shadow: long-distance gamma band synchronization of human brain activity. *Nature* 397, 430–433.
- Roe, A.W., and Ts'o, D.Y. (1995). Visual topography in primate V2: multiple representation across functional stripes. *J. Neurosci.* 15, 3689–3715.
- Roelfsema, P.R., and Singer, W. (1998). Detecting connectedness. *Cereb. Cortex* 8, 385–396.
- Roelfsema, P.R., König, P., Engel, A.K., Sireteanu, R., and Singer, W. (1994). Reduced synchronization in the visual cortex of cats with strabismic amblyopia. *Eur. J. Neurosci.* 6, 1645–1655.
- Roelfsema, P.R., Engel, A.K., König, P., and Singer, W. (1996). The role of neuronal synchronization in response selection: A biologically plausible theory of structured representations in the visual cortex. *J. Cogn. Neurosci.* 8, 603–625.
- Roelfsema, P.R., Engel, A.K., König, P., and Singer, W. (1997). Visuo-motor integration is associated with zero time-lag synchronization among cortical areas. *Nature* 385, 157–161.
- Rolls, D.T., and Tovee, M.J. (1994). Processing speed in the cerebral cortex and the neurophysiology of visual masking. *Proc. R. Soc. Lond. B Biol. Sci.* 257, 9–15.
- Rolls, E., and Tovee, M. (1995). The responses of single neurons in the temporal visual cortical areas of the macaque when more than one stimulus is present in the receptive field. *Exp. Brain Res.* 103, 409–420.
- Rosenblatt, F. (1961). *Principles of Neurodynamics: Perceptions and the Theory of Brain Mechanisms*. (Washington, CD: Spartan Books).
- Rosenquist, A.C. (1985). Connections of visual cortical areas in the cat. In *Cerebral Cortex*, A. Peters and E.G. Jones, eds. (New York: Plenum Press).
- Rougeul, A., Bouyer, J.J., Dedet, L., and Debray, O. (1979). Fast somato-parietal rhythms during combined focal attention and immobility in baboon and squirrel monkey. *Electroenceph. Clin. Neurophysiol.* 46, 310–319.
- Saarinen, J. (1996a). Localization and discrimination of "pop-out" target. *Vision Res.* 36, 313–316.
- Saarinen, J. (1996b). Target localization and identification in rapid visual search. *Perception* 25, 305–312.
- Sagi, D., and Julesz, B. (1985). "Where" and "what" in vision. *Science* 228, 1217–1219.
- Saito, H., Yukie, M., Tanaka, K., Hikosaka, K., Fukada, Y., and Iwai, E. (1986). Integration of direction signals of image motion in the superior temporal sulcus of the macaque monkey. *J. Neurosci.* 6, 145–157.
- Sakai, K., and Miyashita, Y. (1991). Neural organization for the long-term memory of paired associates. *Nature* 354, 152–155.
- Sakai, K., and Miyashita, Y. (1994). Neuronal tuning to learned complex forms in vision. *Neuroreport* 5, 829–832.
- Sakata, H., Taira, M., Murata, A., and Mine, S. (1995). Neural mechanisms of visual guidance of hand action in the parietal cortex of the monkey. *Cereb. Cortex* 5, 429–438.
- Salin, P.A., and Bullier, J. (1995). Corticocortical connections in the visual system: structure and function. *Physiol. Rev.* 75, 107–154.
- Sanes, J.N., and Donoghue, J.P. (1993). Oscillations in local field potentials of the primate motor cortex during voluntary movement. *Proc. Natl. Acad. Sci. USA* 90, 4470–4474.
- Sato, T. (1989). Interactions of visual stimuli in the receptive fields of inferior temporal neurons in awake monkeys. *Exp. Brain Res.* 77, 23–30.
- Schein, S.J., and Desimone, R. (1990). Spectral properties of V4 neurons in the macaque. *J. Neurosci.* 10, 3369–3389.
- Schein, S.J., Marrocco, R.T., and de Monasterio, F.M. (1982). Is there a high concentration of color-selective cells in area V4 of monkey visual cortex? *J. Neurophysiol.* 47, 193–213.
- Schiller, J., Schiller, Y., Stuart, G., and Sakmann, B. (1997). Calcium action potentials restricted to distal apical dendrites of rat neocortical pyramidal neurons. *J. Physiol.* 505, 605–616.
- Schmidt, K.E., Goebel, R., Löwel, S., and Singer, W. (1997a). The perceptual grouping criterion of collinearity is reflected by anisotropies of connections in the primary visual cortex. *Eur. J. Neurosci.* 9, 1083–1089.
- Schmidt, K.E., Kim, D.-S., Singer, W., Bonhoeffer, T., and Löwel, S. (1997b). Functional specificity of long-range intrinsic and interhemispheric connections in the visual cortex of strabismic cats. *J. Neurosci.* 17, 5480–5492.
- Schmolesky, M.T., Wang, Y., Hanes, D.P., Thompson, K.G., Leutgeb, S., Schall, J.D., and Leventhal, A.G. (1998). Signal timing across the macaque visual system. *J. Neurophysiol.* 79, 3272–3278.
- Schroeder, C.E., Mehta, A.D., and Givre, S.J. (1998). A spatiotemporal profile of visual system activation revealed by current source density analysis in the awake macaque. *Cereb. Cortex* 8, 575–592.
- Schuster, H.G., and Wagner, P. (1990). A model for neuronal oscillations in the visual cortex. 2. Phase description of the feature dependent synchronization. *Biol. Cybern.* 64, 83–85.
- Schwarz, C., and Bolz, J. (1991). Functional specificity of the long-range horizontal connections in cat visual cortex: a cross-correlation study. *J. Neurosci.* 11, 2995–3007.
- Schwindt, P.C., and Crill, W.E. (1995). Amplification of synaptic current by persistent sodium conductance in apical dendrite of neocortical neurons. *J. Neurophysiol.* 74, 2220–2224.
- Seidemann, E., and Newsome, W.T. (1999). Effect of spatial attention on the responses of area MT neurons. *J. Neurophysiol.* 81, 1783–1794.
- Sejnowski, T.J. (1981). Skeleton filters in the brain. In *Parallel Models of Associative Memory*, G.E. Hinton and J.A. Anderson, eds. (Hillsdale, NJ: Lawrence Erlbaum Associates).
- Sereno, M.I., and Allman, J.M. (1991). Cortical visual areas in mammals. In *The Neural Basis of Visual Function*, A. Leventhal, ed. (New York: MacMillan).
- Sereno, A.B., and Maunsell, J.H.R. (1998). Shape selectivity in primate lateral intraparietal cortex. *Nature* 395, 500–503.
- Sestokas, A.K., and Lehmkuhle, S. (1988). Response variability of X- and Y-cells in the dorsal lateral geniculate nucleus of the cat. *J. Neurophysiol.* 59, 317–325.
- Shadlen, M.N., and Movshon, J.A. (1999). Synchrony unbound: a critical evaluation of the temporal binning hypothesis. *Neuron* 24, this issue, 67–77.
- Shadlen, M.N., and Newsome, W.T. (1994). Noise, neural codes and cortical organization. *Curr. Opin. Neurobiol.* 4, 569–579.
- Shadlen, M., and Newsome, W. (1995). Is there a signal in the noise? *Curr. Opin. Neurobiol.* 5, 248–250.
- Shadlen, M.N., and Newsome, W.T. (1996). Motion perception: seeing and deciding. *Proc. Natl. Acad. Sci. USA* 93, 628–633.
- Shadlen, M.N., and Newsome, W.T. (1998). The variable discharge of cortical neurons: implications for connectivity, computation, and information coding. *J. Neurosci.* 18, 3870–3896.
- Shastri, L., and Ajanagadde, V. (1993). From simple associations to systematic reasoning. *Behav. Brain Sci.* 16, 417–494.
- Sheinberg, D.L., and Logothetis, N.K. (1997). The role of temporal cortical areas in perceptual organization. *Proc. Natl. Acad. Sci. USA* 94, 3408–3413.

- Shimojo, S., Silverman, G.H., and Nakayama, K. (1989). Occlusion and the solution to the aperture problem for motion. *Vision Res.* *29*, 619–626.
- Sillito, A.M., Grieve, K.L., Jones, H.L., Cuderio, J., and Davis, J. (1995). Visual cortical mechanisms detecting focal orientation discontinuities. *Nature* *378*, 492–496.
- Silverman, M.S., Grosz, D.H., DeValois, R.L., and Elfar, S.D. (1989). Spatial-frequency organization in primate striate cortex. *Proc. Natl. Acad. Sci. USA* *86*, 711–715.
- Simons, D.J., and Levin, D.T. (1997). Change blindness. *Trends Cogn. Sci.* *1*, 261–268.
- Singer, W. (1993). Synchronization of cortical activity and its putative role in information processing and learning. *Annu. Rev. Physiol.* *55*, 349–374.
- Singer, W. (1994). Putative functions of temporal correlations in neocortical processing. In *Large-Scale Neuronal Theories of the Brain*, C. Koch and J.L. Davis, eds. (Cambridge, MA: MIT Press).
- Singer, W. (1995). Development and plasticity of cortical processing architectures. *Science* *270*, 758–764.
- Singer, W. (1999a). Response synchronization: a universal coding strategy for the definition of relations. In *The Cognitive Neurosciences*, M.S. Gazzaniga, ed. (Cambridge, MA: MIT Press).
- Singer, W. (1999b). Neuronal synchrony: a versatile code for the definition of relations? *Neuron* *24*, this issue, 49–65.
- Singer, W., and Gray, C.M. (1995). Visual feature integration and the temporal correlation hypothesis. *Annu. Rev. Neurosci.* *18*, 555–586.
- Singer, W., Engel, A.K., Kreiter, A.K., Munk, M.H.J., Neuenschwander, S., and Roelfsema, P.R. (1997). Neuronal assemblies: necessity, signature and detectability. *Trends Cogn. Sci.* *1*, 252–261.
- Skottun, B.C., Bradley, A., Sclar, G., Ohzawa, I., and Freeman, R.D. (1987). The effects of contrast on visual orientation and spatial frequency discrimination: a comparison of single cells and behavior. *J. Neurophysiol.* *57*, 773–786.
- Snyder, L.H., Batista, A.P., and Andersen, R.A. (1997). Coding of intention in the posterior parietal cortex. *Nature* *386*, 167–170.
- Sompolinsky, H., Golomb, D., and Kleinfeld, D. (1990). Global processing of visual stimuli in a neural network of coupled oscillators. *Proc. Natl. Acad. Sci. USA* *87*, 7200–7204.
- Sperry, R.W., Miner, N., and Myers, R.E. (1955). Visual pattern perception following subpial slicing and tantalum wire implantations in the visual cortex. *J. Comp. Physiol. Psychol.* *48*, 50–58.
- Spitzer, H., Desimone, R., and Moran, J. (1988). Increased attention enhances both behavioral and neuronal performance. *Science* *240*, 338–340.
- Sporns, O., Gally, J.A., Reeke, G.N., and Edelman, G.M. (1989). Reentrant signaling among simulated neuronal groups leads to coherency in their oscillatory activity. *Proc. Natl. Acad. Sci. USA* *86*, 7265–7269.
- Sporns, O., Tononi, G., and Edelman, G.M. (1991). Modeling perceptual grouping and figure ground segregation by means of active reentrant connections. *Proc. Natl. Acad. Sci. USA* *88*, 129–133.
- Stemmler, M., Usher, M., and Niebur, E. (1995). Lateral interactions in primary visual cortex: a model bridging physiology and psychophysics. *Science* *269*, 1877–1880.
- Steriade, M., Timofeev, I., Durmuller, N., and Grenier, F. (1998). Dynamic properties of corticothalamic neurons and local cortical interneurons generating fast rhythmic (30–40 Hz) spike-bursts. *J. Neurophysiol.* *79*, 483–490.
- Steriade, M. (1999). Coherent oscillations and short-term plasticity in corticothalamic networks. *Trends Neurosci.* *22*, 337–345.
- Stevens, C.F., and Wang, Y. (1995). Facilitation and depression at single central synapses. *Neuron* *14*, 795–802.
- Stevens, C.F., and Zador, A.M. (1998). Input synchrony and the irregular firing of cortical neurons. *Nat. Neurosci.* *1*, 210–217.
- Stoner, G.R., and Albright, T.D. (1992). Neural correlates of perceptual motion coherence. *Nature* *358*, 412–414.
- Stoner, G.R., Albright, T.D., and Ramachandran, V.S. (1990). Transparency and coherence in human motion perception. *Nature* *344*, 153–155.
- Stopfer, M., Bhagavan, S., Smith, B.H., and Laurent, G. (1997). Impaired odor discrimination on desynchronization of odor-encoding neural assemblies. *Nature* *390*, 70–74.
- Storm, J.F. (1990). Potassium currents in hippocampal pyramidal cells. *Prog. Brain Res.* *83*, 161–187.
- Stryker, M.P. (1989). Cortical physiology: is grandmother an oscillation? *Nature* *338*, 297–298.
- Stuart, G., and Sakmann, B. (1995). Amplification of EPSPs by axosomatic sodium channels in neocortical pyramidal neurons. *Neuron* *15*, 1065–1076.
- Suzuki, S., and Cavanagh, P. (1995). Facial organization blocks access to low-level features: an object inferiority effect. *J. Exp. Psychol. Hum. Percept. Perform.* *21*, 901–913.
- Szentagotai, J. (1973). Synaptology of the visual cortex. In *Handbook of Sensory Physiology VII/3B: Visual Centers in the Brain*, R. Jung, ed. (New York: Springer-Verlag).
- Tallon-Baudry, C., and Bertrand, O. (1999). Oscillatory gamma activity in humans and its role in object representation. *Trends Cogn. Sci.* *3*, 151–162.
- Tallon-Baudry, C., Bertrand, O., Delpuech, C., and Pernier, J. (1996). Stimulus specificity of phase-locked and non-phase-locked 40 Hz visual responses in human. *J. Neurosci.* *16*, 4240–4249.
- Tallon-Baudry, C., Bertrand, O., Delpuech, C., and Pernier, J. (1997). Oscillatory gamma band (30–70 Hz) activity induced by a visual search task in humans. *J. Neurosci.* *17*, 722–734.
- Tallon-Baudry, C., Bertrand, O., Peronnet, F., and Pernier, J. (1998). Induced gamma band activity during the delay of a visual short-term memory task in humans. *J. Neurosci.* *18*, 4244–4254.
- Tallon-Baudry, C., Kreiter, A.K., and Bertrand, O. (1999). Sustained and transient oscillatory responses in the gamma and beta bands in a visual short-term memory task in humans. *Vis. Neurosci.*, in press.
- Tanaka, K. (1993). Neuronal mechanisms of object recognition. *Science* *262*, 685–688.
- Tanaka, K. (1996). Inferotemporal cortex and object vision: stimulus selectivity and columnar organization. *Annu. Rev. Neurosci.* *19*, 109–139.
- Tanaka, K., and Saito, H.-A. (1989). Analysis of motion of the visual field by direction, expansion/contraction, and rotation cells clustered in the dorsal part of the medial superior temporal area of the macaque monkey. *J. Neurophysiol.* *62*, 626–641.
- Tanaka, K., Hikosaka, K., Saito, H., Yukie, M., Fukada, Y., and Iwai, E. (1986a). Analysis of local and wide-field movements in the superior temporal visual areas of the macaque monkey. *J. Neurosci.* *6*, 134–144.
- Tanaka, M., Weber, H., and Creutzfeldt, O.D. (1986b). Visual properties and spatial distribution of neurones in the visual association area on the prelunate gyrus of the awake monkey. *Exp. Brain Res.* *65*, 11–37.
- Tanaka, K., Fukada, Y., and Saito, H.A. (1989). Underlying mechanisms of the response specificity of expansion/contraction and rotation cells in the dorsal part of the medial superior temporal area of the macaque monkey. *J. Neurophysiol.* *62*, 642–656.
- Tarr, M.J., and Bulthoff, H.H. (1995). Is human object recognition better described by geon-structural-descriptions or by multiple-views? *J. Exp. Psychol. Hum. Percept. Perform.*, in press.
- Theeuwes, J., and Kooi, J.L. (1994). Parallel search for a conjunction of shape and contrast polarity. *Vision Res.* *34*, 3013–3016.
- Thomson, A.M., and Deuchars, J. (1997). Synaptic interactions in neocortical local circuits: dual intracellular recordings in vitro. *Cereb. Cortex* *7*, 510–522.
- Thomson, A.M., and West, D.C. (1993). Fluctuations in pyramidal-pyramidal excitatory postsynaptic potentials modified by presynaptic firing pattern and postsynaptic membrane potential using paired intracellular recordings in rat neocortex. *Neuroscience* *54*, 329–346.
- Thomson, A., Deuchars, J., and West, D. (1993). Single axon excitatory postsynaptic potentials in neocortical interneurons exhibit pronounced paired pulse facilitation. *Neuroscience* *54*, 347–360.
- Thorpe, S., Fize, D., and Marlot, C. (1996). Speed of processing in the human visual system. *Nature* *381*, 520–522.

- Tiitinen, H., Sinkkonen, J., Reinikainen, K., Alho, K., Lavikainen, J., and Naatanen, R. (1993). Selective attention enhances the auditory 40-Hz transient response in humans. *Nature* 364, 59–60.
- Tipper, S.P., Weaver, B., Jerreat, L.M., and Burak, A.L. (1994). Object-based and environment-based inhibition of return of visual attention. *J. Exp. Psychol. Hum. Percept. Perform.* 20, 478–499.
- Tipper, S.P., and Weaver, B. (1998). The medium of attention: location-based, object-based, or scene-based? In *Visual Attention*, Volume 8, R.D. Wright, ed. (Oxford: Oxford University Press).
- Tong, F., Nakayama, K., Vaughan, J.T., and Kanwisher, N. (1998). Binocular rivalry and visual awareness in human extrastriate cortex. *Neuron* 21, 753–759.
- Tononi, G., and Edelman, G.M. (1998). Consciousness and complexity. *Science* 282, 1846–1851.
- Tononi, G., Sporns, O., and Edelman, G. (1992). Reentry and the problem of integrating multiple cortical areas: simulation of dynamic integration in the visual system. *Cereb. Cortex* 2, 310–335.
- Tononi, G., Srinivasan, R., Russell, D.P., and Edelman, G.M. (1998). Investigating neural correlates of conscious perception by frequency-tagged neuromagnetic responses. *Proc. Natl. Acad. Sci. USA* 95, 3198–3203.
- Tootell, R.B.H., and Hamilton, S.L. (1989). Functional anatomy of the second visual area (V2) in the macaque. *J. Neurosci.* 9, 2620–2644.
- Tootell, R.B.H., and Taylor, J.B. (1995). Anatomical evidence for MT and additional cortical visual areas in humans. *Cereb. Cortex* 1, 39–55.
- Tootell, R.B.H., Dale, A.M., Sereno, M.I., and Malach, R. (1996). New images from human visual cortex. *Trends Neurosci.* 19, 481–489.
- Tovee, M., and Rolls, E. (1992a). Oscillatory activity is not evident in the primate temporal visual cortex with static stimuli. *Neuroreport* 3, 369–372.
- Tovee, M.J., and Rolls, E.T. (1992b). The functional nature of neuronal oscillations. *Trends Neurosci.* 15, 387.
- Toyama, K., Kimura, M., and Tanaka, K. (1981a). Cross-correlation analysis of interneuronal connectivity in cat visual cortex. *J. Neurophysiol.* 46, 191–201.
- Toyama, K., Kimura, M., and Tanaka, K. (1981b). Organization of cat visual cortex as investigated by cross-correlation techniques. *J. Neurophysiol.* 46, 202–214.
- Traub, R.D., Wong, R.K.S., Miles, R., and Michelson, H.B. (1991). A model of a CA3 hippocampal pyramidal neuron incorporating voltage-clamp data on intrinsic conductances. *J. Neurophysiol.* 66, 635–650.
- Traub, R.D., Whittington, M.A., Stanford, I.M., and Jefferys, J.G. (1996). A mechanism for generation of long-range synchronous fast oscillations in the cortex. *Nature* 383, 621–624.
- Treisman, A. (1982). Perceptual grouping and attention in visual search for features and for objects. *J. Exp. Psychol. Hum. Percept. Perform.* 8, 194–214.
- Treisman, A. (1988). Features and objects: the fourteenth Bartlett memorial lecture. *Quart. J. Exp. Psychol.* 40A, 201–237.
- Treisman, A. (1991). Search, similarity and the integration of features between and within dimensions. *J. Exp. Psychol. Hum. Percept. Perform.* 27, 652–676.
- Treisman, A. (1992a). Perceiving and re-perceiving objects. *Am. Psychol.* 47, 862–875.
- Treisman, A. (1992b). Spreading suppression or feature integration? A reply to Duncan and Humphreys. *J. Exp. Psychol. Hum. Percept. Perform.* 18, 589–593.
- Treisman, A. (1993). The perception of features and objects. In *Attention: Selection, Awareness and Control: A Tribute to Donald Broadbent*, A. Baddeley and L. Weiskrantz, eds. (Oxford: Clarendon Press).
- Treisman, A. (1995). Modularity and attention: is the binding problem real? *Vis. Cogn.* 2, 303–311.
- Treisman, A. (1996). The binding problem. *Curr. Opin. Neurobiol.* 6, 171–178.
- Treisman, A. (1998). Feature binding, attention and object perception. *Philos. Trans. R. Soc. Lond. B Biol. Sci.* 353, 1295–1306.
- Treisman, A., and Gelade, G. (1980). A feature-integration theory of attention. *Cogn. Psychol.* 12, 97–136.
- Treisman, A., and Gormican, S. (1988). Feature analysis in early vision: evidence from search asymmetries. *Psychol. Rev.* 95, 15–48.
- Treisman, A., and Kanwisher, N.K. (1998). Perceiving visually-presented objects: recognition, awareness, and modularity. *Curr. Opin. Neurobiol.* 8, 218–226.
- Treisman, A., and Sato, S. (1990). Conjunction search revisited. *J. Exp. Psychol. Hum. Percept. Perform.* 16, 459–478.
- Treisman, A., and Schmidt, H. (1982). Illusory conjunctions in the perception of objects. *Cogn. Psychol.* 14, 107–141.
- Treisman, A., and Souther, J. (1986). Illusory words: the roles of attention and of top-down constraints in conjoining letters to form words. *J. Exp. Psychol. Hum. Percept. Perform.* 12, 3–17.
- Treue, S., and Andersen, R.A. (1996). Neural responses to velocity gradients in macaque cortical area MT. *Vis. Neurosci.* 13, 797–804.
- Treue, S., and Maunsell, J.H.R. (1996). Attentional modulation of visual motion processing in cortical areas MT and MST. *Nature* 382, 539–541.
- Triesch, J., and von der Malsburg, C. (1996). Binding—a proposed experiment and a model. In *Proceedings of the Proceedings of the International Conference on Artificial Neural Networks 1996* (New York: Springer-Verlag).
- Tsal, Y. (1989). Do illusory conjunctions support feature integration theory? A critical review of theory and findings. *J. Exp. Psychol. Hum. Percept. Perform.* 15, 394–400.
- Ts'o, D., and Gilbert, C. (1988). The organization of chromatic and spatial interactions in the primate striate cortex. *J. Neurosci.* 8, 1712–1727.
- Ts'o, D.Y., Gilbert, C.D., and Wiesel, T.N. (1986). Relationships between horizontal interactions and functional architecture in cat striate cortex as revealed by cross-correlation analysis. *J. Neurosci.* 6, 1160–1170.
- Tsotsos, J.K. (1990). Analyzing vision at the complexity level. *Behav. Brain Sci.* 13, 423–445.
- Tsotsos, J.K. (1995). Toward a computational model of visual attention. In *Early Vision and Beyond*, T.V. Papathomas, ed. (Cambridge, MA: MIT Press).
- Tsotsos, J.K., Culhane, S.N., Wai, W.Y.K., Lai, Y., Davis, N., and Nuflo, F. (1995). Modeling visual attention via selective tuning. *Artif. Intell.* 78, 507–545.
- Ullman, S. (1996). *High-Level Vision* (Cambridge, MA: MIT Press).
- Ungerleider, L., and Haxby, J. (1994). “What” and “Where” in the human brain. *Curr. Opin. Neurobiol.* 4, 157–165.
- Ungerleider, L.G., and Mishkin, M. (1982). Two cortical visual systems. In *Analysis of Visual Behavior*, D.J. Ingle, M.A. Goodale, and R.J.W. Mansfield, eds. (Cambridge, MA: MIT Press).
- Ungerleider, L.G., Gaffan, D., and Pelak, V.S. (1989). Projections from inferior temporal cortex to prefrontal cortex via the uncinate fascicle in rhesus monkeys. *Exp. Brain Res.* 76, 473–484.
- Usher, M., and Donnelly, N. (1998). Visual synchrony affects binding and segmentation in perception. *Nature* 394, 179–182.
- Usrey, W.M., and Reid, R.C. (1999). Synchronous activity in the visual system. *Annu. Rev. Physiol.* 61, 435–456.
- Vaadia, E., and Aertsen, A. (1992). Coding and computation in the cortex: single-neuron activity and cooperative phenomena. In *Information Processing in the Cortex: Experiments and Theory*, A. Aertsen and V. Braitenberg, eds. (New York: Springer-Verlag).
- Vaadia, E., Ahissar, E., Bergman, H., and Lavner, Y. (1991). Correlated activity of neurons: a neural code for higher brain functions? In *Neuronal Cooperativity*, J. Kruger, ed. (Berlin: Springer-Verlag).
- Vaadia, E., Haalman, I., Abeles, M., Bergman, H., Prut, Y., Slovin, H., and Aertsen, A. (1995). Dynamics of neuronal interactions in monkey cortex in relation to behavioural events. *Nature* 373, 515–518.
- Van Essen, D.C., and Anderson, C.H. (1990). Information processing strategies and pathways in the primate retina and visual cortex. In *An Introduction to Neural and Electronic Networks*, S.F. Zornetzer, J.L. Davis, and C. Lau, eds. (New York: Academic Press).
- Van Essen, D.C., and Gallant, J.L. (1994). Neural mechanisms of form and motion processing in the primate visual system. *Neuron* 13, 1–10.

- Van Essen, D.C., and Zeki, S.M. (1978). The topographic organization of rhesus monkey prestriate cortex. *J. Physiol. (Lond.)* 277, 193–226.
- Van Essen, D.C., Anderson, C.H., and Felleman, D.J. (1992). Information processing in the primate visual system: an integrated systems perspective. *Science* 255, 419–423.
- van Vreeswijk, D., Abbott, L.F., and Ermentrout, G.B. (1994). When inhibition not excitation synchronizes neural firing. *J. Comput. Neurosci.* 7, 313–321.
- Varela, F.J. (1995). Resonant cell assemblies: a new approach to cognitive functions and neuronal synchrony. *Biol. Res.* 28, 81–95.
- Vecera, S.P., and Farah, M.J. (1994). Does visual attention select objects or locations? *J. Exp. Psychol. Gen.* 123, 146–160.
- Vogels, R., and Orban, G.A. (1994). Activity of inferior temporal neurons during orientation discrimination with successively presented gratings. *J. Neurophysiol.* 71, 1428–1451.
- Volgushev, M., Chistiakova, M., and Singer, W. (1998). Modification of discharge patterns of neocortical neurons by induced oscillations of the membrane potential. *Neuroscience* 83, 15–25.
- von der Heydt, R., and Dursteler, M.R. (1993). Visual search: monkeys detect conjunctions as fast as features. *Invest. Ophthalmol. Vis. Sci.* 34, 1288.
- von der Malsburg, C. (1981). The correlation theory of brain function. MPI Biophysical Chemistry, Internal Report 81–2. Reprinted in *Models of Neural Networks II* (1994), E. Domany, J.L. van Hemmen, and K. Schulten, eds. (Berlin: Springer).
- von der Malsburg, C. (1985). Nervous structures with dynamical links. *Ber. Bunsenges. Phys. Chem.* 89, 703–710.
- von der Malsburg, C. (1986). Am I thinking assemblies? In *Proceedings of the Trieste Meeting on Brain Theory*, G. Palm and A. Aertsen, eds. (Springer: Berlin).
- von der Malsburg, C. (1988). Pattern recognition by labeled graph matching. *Neural Networks* 1, 141–148.
- von der Malsburg, C. (1995). Binding in models of perception and brain function. *Curr. Opin. Neurobiol.* 5, 520–526.
- von der Malsburg, C. (1999). The what and why of binding: the modeler's perspective. *Neuron* 24, this issue, 95–104.
- von der Malsburg, C., and Bienenstock, E. (1987). A neural network for the retrieval of superimposed connection patterns. *Europhys. Lett.* 3, 1243–1249.
- von der Malsburg, C., and Buhmann, J. (1992). Sensory segmentation with coupled neural oscillators. *Biol. Cybern.* 67, 233–242.
- von der Malsburg, C., and Reiser, K. (1995). Pose invariant object recognition in a neural system. In *Proceedings of the International Conference on Artificial Neural Networks 1995*, F. Fogelman-Souli, J.C. Rault, P. Gallinari, and G. Dreyfus, eds. (New York: Springer-Verlag).
- von der Malsburg, C., and Schneider, W. (1986). A neural cocktail-party processor. *Biol. Cybern.* 54, 29–40.
- von der Malsburg, C., and Singer, W. (1991). Principles of cortical network organization. In *Neurobiology of Neocortex*, P. Rakic and W. Singer, eds. (New York: John Wiley).
- von Helmholtz, H.L.F. (1925). *Treatise on Physiological Optics* (New York: Dover Press).
- Wallis, G., and Rolls, E. (1997). A model of invariant object recognition in the visual system. *Prog. Neurobiol.* 51, 167–294.
- Wandell, B.A. (1999). Computational neuroimaging of human visual cortex. *Annu. Rev. Neurosci.* 22, 145–173.
- Wang, X.-J. (1999). Fast burst firing and short-term synaptic plasticity: a model of neocortical chattering neurons. *Neuroscience* 89, 347–362.
- Wang, X.-J., and Buzsaki, G. (1996). Gamma oscillation by synaptic inhibition in a hippocampal interneuronal network model. *J. Neurosci.* 16, 6402–6413.
- Wang, D.L., Buhmann, J., and von der Malsburg, C. (1990). Pattern segmentation in associative memory. *Neural Comput.* 2, 94–106.
- Wang, Q., Cavanagh, P., and Green, M. (1994). Familiarity and pop-out in visual search. *Percept. Psychophys.* 56, 495–500.
- Wehr, M., and Laurent, G. (1996). Odour encoding by temporal sequences of firing in oscillating neural assemblies. *Nature* 384, 162–166.
- Weisstein, N. (1973). Beyond the yellow Volkswagen detector and the grandmother cell: a general strategy for the exploration of operations in human pattern recognition. In *Contemporary Issues in Cognitive Psychology: The Loyola Symposium*, R.L. Solso, ed. (Washington, DC: Winston/Wiley).
- Wertheimer, M. (1923). Untersuchungen zur Lehre der Gestalt. *Psychol. Forschung* 4, 301–350.
- Wertheimer, M. (1955). Laws of organization in perceptual forms. In *A Source Book of Gestalt Psychology*, W.D. Ellis, ed. (London: Routledge and Kegan Paul).
- Wespapat, V., Tennigkeit, F., and Singer, W. (1999). Oscillations and long-term synaptic plasticity in rat visual cortex. In *From Molecular Neurobiology to Clinical Neuroscience: Proceedings of the 1st Göttingen Conference of the German Neuroscience Society, Volume 1, 27th Göttingen Neurobiology Conference*, N. Elsner and U. Eysel, eds. (Stuttgart: Thieme-Verlag).
- Whittington, M.A., Traub, R.D., and Jefferys, J.G.R. (1995). Synchronized oscillations in interneuron networks driven by metabotropic glutamate receptor activation. *Nature* 373, 612–615.
- Wickelgren, W. (1969). Context-sensitive coding, associative memory, and serial order in (speech) behavior. *Psychol. Rev.* 76, 1–15.
- Wilson, M., and Bower, J.M. (1992). Cortical oscillations and temporal interactions in a computer simulation of piriform cortex. *J. Neurophysiol.* 67, 981–995.
- Wilson, M.A., and McNaughton, B.L. (1993). Dynamics of the hippocampal ensemble code for space. *Science* 261, 1055–1058.
- Wilson, F.A., Scalaidhe, S.P., and Goldman-Rakic, P.S. (1993). Dissociation of object and spatial processing domains in primate prefrontal cortex. *Science* 260, 1955–1958.
- Wiskott, L. (1999). The role of topographical constraints in face recognition. *Pattern Recog. Lett.* 20, 89–96.
- Wiskott, L., and von der Malsburg, C. (1995). Face recognition by dynamic link matching. In *Lateral Interactions in the Cortex: Structure and Function* (electronic book), J. Sirosh, R. Miikkulainen, and Y. Choe, eds., www.cs.utexas.edu/users/nn/web-pubs/htmlbook96.
- Wolfe, J.M. (1992). "Effortless" texture segmentation and "parallel" visual search are not the same thing. *Vision Res.* 32, 757–763.
- Wolfe, J.M. (1994a). Guided Search 2.0: a revised model of visual search. *Psychon. Bull. Rev.* 1, 202–238.
- Wolfe, J.M. (1994b). Visual search in continuous, naturalistic stimuli. *Invest. Ophthalmol. Vis. Sci.* 35, 13–28.
- Wolfe, J.M. (1996). Extending Guided Search: why Guided Search needs a preattentive "item map." In *Converging Operations in the Study of Visual Selective Attention*, A. Kramer, G.H. Cole, and G.D. Logan, eds. (Washington, DC: American Psychological Association).
- Wolfe, J.M. (1998). What do 1,000,000 trials tell us about visual search? *Psychol. Sci.* 9, 33–39.
- Wolfe, J., and Bennett, S. (1996). Preattentive object files: shapeless bundles of basic features. *Vision Res.* 37, 25–44.
- Wolfe, J.M., and Cave, K.R. (1999). The psychophysical evidence for a binding problem in human vision. *Neuron* 24, this issue, 11–17.
- Wolfe, J.M., and Gancarz, G. (1996). Guided Search 3.0: a model of visual search catches up with Jay Enoch 40 years later. In *Basic and Clinical Applications of Vision Science*, V. Lakshminarayanan, ed. (Dordrecht, Netherlands: Kluwer Academic).
- Wolfe, J.M., Cave, K.R., and Franzel, S.L. (1989). Guided Search: an alternative to the Feature Integration model for visual search. *J. Exp. Psychol. Hum. Percept. Perform.* 15, 419–433.
- Wolfe, J.M., Chun, M.M., and Friedman-Hill, S.R. (1995). Making use of text on gradients: visual search and perceptual grouping exploit the same parallel processes in different ways. In *Early Vision and Beyond*, T. Pappathomas, C. Chubb, A. Gorea, and E. Kowler, eds. (Cambridge, MA: MIT Press).
- Würtz, R. (1997). Object recognition robust under translations, deformations, and changes in background. *IEEE Trans. Pattern Anal. Machine Intell.* 19.
- Yantis, S., and Gibson, B.S. (1994). Object continuity in apparent motion and attention. *Can. J. Exp. Psychol.* 48, 182–204.
- Yen, S.-C., and Finkel, L.H. (1998). Extraction of perceptually salient contours by striate cortical networks. *Vision Res.* 38, 719–741.

- Yen, S.-C., Menschik, E.D., and Finkel, L.H. (1999). Perceptual grouping in striate cortical networks mediated by synchronization and desynchronization. *Neurocomputing*, in press.
- Yeshurun, Y., and Carrasco, M. (1998). Attention improves or impairs visual performance by enhancing spatial resolution. *Nature* *396*, 72–75.
- Yeshurun, Y., and Carrasco, M. (1999). Spatial attention improves performance in spatial resolution tasks. *Vision Res.* *39*, 293–306.
- Ylinen, A., Sik, A., Bragin, A., Nadasdy, Z., Jando, G., Szabo, I., and Buzsaki, G. (1995). Sharp wave-associated high-frequency oscillation (200 Hz) in the intact hippocampus: network and intracellular mechanisms. *J. Neurosci.* *15*, 30–46.
- Yoshioka, T., Blasdel, G.G., Levitt, J.B., and Lund, J.S. (1996). Relation between patterns of intrinsic lateral connectivity, ocular dominance, and cytochrome oxidase-reactive regions in macaque monkey striate cortex. *Cereb. Cortex* *6*, 297–310.
- Young, M.P., and Yamane, S. (1992). Sparse population coding of faces in the inferotemporal cortex. *Science* *256*, 1327–1331.
- Young, M.P., Tanaka, K., Yamane, S. (1992). On oscillating neuronal responses in the visual cortex of the monkey. *J. Neurophysiol.* *67*, 1464–1474.
- Yu, A.C., and Margoliash, D. (1996). Temporal hierarchical control of singing in birds. *Science* *273*, 1871–1875.
- Yuste, R., and Tank, D.W. (1996). Dendritic integration in mammalian neurons, a century after Cajal. *Neuron* *16*, 701–716.
- Zeki, S.M. (1978). Functional specialisation in the visual cortex of the rhesus monkey. *Nature* *274*, 423–428.
- Zeki, S. (1983). The distribution of wavelength and orientation selective cells in different areas of monkey visual cortex. *Proc. R. Soc. Lond. B Biol. Sci.* *217*, 449–470.
- Zeki, S., and Shipp, S. (1988). The functional logic of cortical connections. *Nature* *335*, 311–317.
- Zhang, X. (1999). Anticipatory inhibition: an intentional non-spatial mechanism revealed with the distractor previewing technique. PhD thesis, Princeton University, Princeton, NJ.
- Zhang, L.I., Tao, H.W., Holt, C.E., Harris, W.A., and Poo, M. (1998). A critical window for cooperation and competition among developing retinotectal synapses. *Nature* *395*, 37–44.
- Zipser, K., Lamme, V.A.F., and Schiller, P.H. (1996). Contextual Modulation in Primary Visual Cortex. *J. Neurosci.* *16*, 7376–7389.
- Zohary, E., and Hochstein, S. (1989). How serial is serial processing in vision? *Perception* *18*, 191–200.
- Zohary, E., Shadlen, M.N., and Newsome, W.T. (1994). Correlated neuronal discharge rate and its implications for psychophysical performance. *Nature* *370*, 140–143.